

**IFE Research Activities  
at UCLA**

**Presentations to  
Mark Wilson, OFES**

**October 30-31, 1996**

**Introductory Remarks  
on UCLA Research Activities  
for IFE**

**Mohamed Abdou**

**Presented to Dr. Mark Wilson, OFES, in a meeting  
at UCLA, October 30-31, 1996**

## **FEAC Panel Review on IFE (July 1996)**

“The IFE Program within OFES must have sufficient BREADTH beyond driver development, to cover those areas which are critical to its feasibility and competitiveness”

### **First Priority:**

- Wall protection scheme evaluations and development.
- Confirmatory simulations of heavy ion driver target performance.

### **Second Priority:**

- Cavity clearing technologies at IFE repetition rates.
- Development of the final focusing optics for laser systems. (It is assumed that final focusing and transport studies for heavy ion beams are undertaken as a part of the accelerator development program.)

### **Third Priority:**

- Target factory studies.
- Work on rep-rated laser systems. This is an important area but until IFE funding increases substantially, development of only the presently most promising driver can be afforded.
- Shielding, blanket and tritium studies.
- Detailed power plant conceptual design studies. The extensive studies made in recent years have identified the principal issues for IFE. It is time now to concentrate on scientific and technological studies on these specific issues.

# UCLA's Role in IFE

We propose that UCLA be the Lead Organization for Chamber Technology (including conducting IFE-Relevant Experiments on NIF)

## Goal (5-year)

Evaluate the scientific feasibility of IFE Wall Protection Schemes

and

Identify the most promising concept(s) for further R&D.

## Approach

- Conduct experiments and develop models to: 1) improve our understanding of the scientific issues, 2) develop a predictive capability.
- Perform an integrated assessment of the most promising concepts (integrated assessment includes fluid flow, heat transfer, mass transfer, materials, neutronics, tritium breeding, activation, etc.).
- Identify the most promising one or two concepts worthy of further development. Identify the most critical issues to the focus of R&D.

# **UCLA is Uniquely Qualified for the Lead Role on IFE Chamber Technology**

1) Very strong modeling, simulation, experimental, computational capabilities and experience in the key disciplines:

- Fluid Mechanics
- Heat & Mass Transfer
- Materials Interactions
- Neutronics
- etc.

2) Demonstrated Capability in Conducting High-Quality R&D Programs

- Free Surface Liquid Metal Experiments and Models
- Self Cooled liquid metals, Fluid Mechanics and Materials Interactions
- Heat and Mass Transfer in breeder ceramics and beryllium
- Neutronics Experiments and Models for nuclear heating, activation and tritium breeding

3) Lead Organization on Technology Testing in ITER

(R&D, engineering scaling, analysis, instrumentation, technical planning, extrapolation.)

**4) Decades of Experience in DESIGN for Magnetic Fusion systems**

**(INTOR, ITER, STARFIRE, TITAN, ARIES, etc.)**

**5) Demonstrated Experience in Design and Innovation for Inertial Fusion System**

**e.g. - Lead Organization on Chamber Technology, Cavity Clearing, Materials, and Nuclear components for PROMETHEUS-L and PROMETHEUS-H**

**6) An integrated and dedicated team of competent research staff and bright graduate students**

**7) Can draw on a very Broad and Strong Base of first-rate Research Programs in related sciences and Technologies in the Mechanical/Aerospace Engineering Department, Physics Department, and the rest of UCLA**

# Most Promising Concepts to be Addressed Now by UCLA

## 1. Thick Liquid Wall

Very High Risk

but Very High Payoff

## 2. Thin Liquid Metal

- Lower Risk
- Solves the high surface heat load blast problem
- Low activation materials need to be used

### Notes

- The present funding level is very limited. With such funding we prepare to focus on the fluid flow and heat transfer issues
- Cavity clearing must be addressed as an integral part of the wall protection effort

## IFE - Relevant Experiments on NIF

- NIF will provide critical data for IFE on target ignition, energy gain and system integration information
- Although NIF lacks a meaningful pulse repetition rate, the significant yield per shot (up to 20 MJ) and other features of the facility allow very useful experiments specifically aimed at energy applications. Examples are:
  - Experiments on Wall Protection Scheme
  - Experiments on final optics
  - Data on High-Dose-Rate neutron effects on materials
  - Data on neutron heating, tritium breeding, activation, and shielding
- Near-Term R&D, e.g. on Wall Protection should provide the data needed to construct energy-relevant experiments on NIF
- These experiments can be part of the DP-ER coordination



# CHAMBER WALL PROTECTION

- Next to Ignition, Chamber Wall Protection is likely to be the most serious challenge to IFE.
- Very high instantaneous loads of x-rays, target debris and neutrons can lead to serious ablation of surfaces and severe damage of structures surrounding the microexplosion:
  - Fatigue would also be a serious issue (>  $10^8$  cycles per year).

But, this is an excellent example of how a very serious technical Problem can be turned into a Potential Opportunity through Innovative Design Solutions that Promise to give IFE unique advantages and Radically eliminate long-term activation of conventional structural materials.

# Thin Liquid Protection of Chamber Wall

FIRST WALL BLANKET MODULE ARRANGEMENT

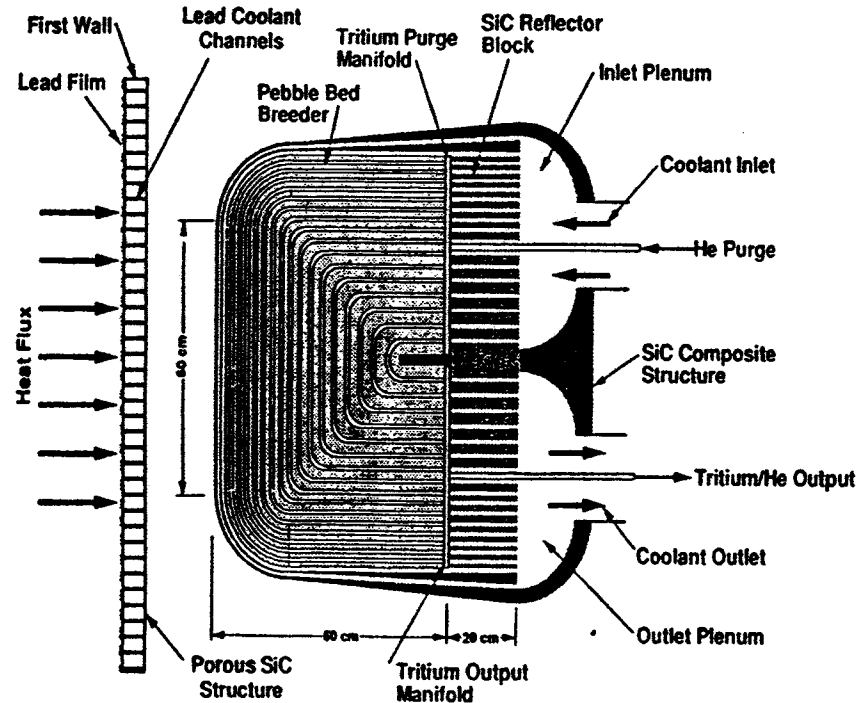
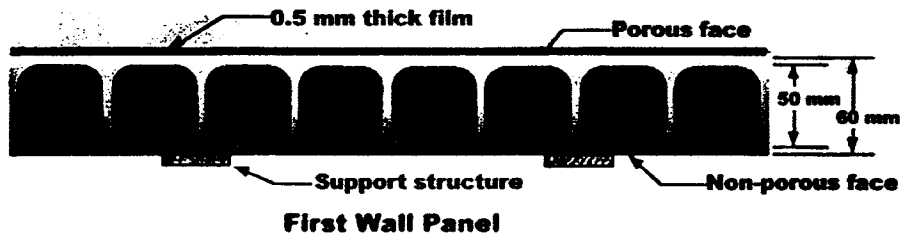
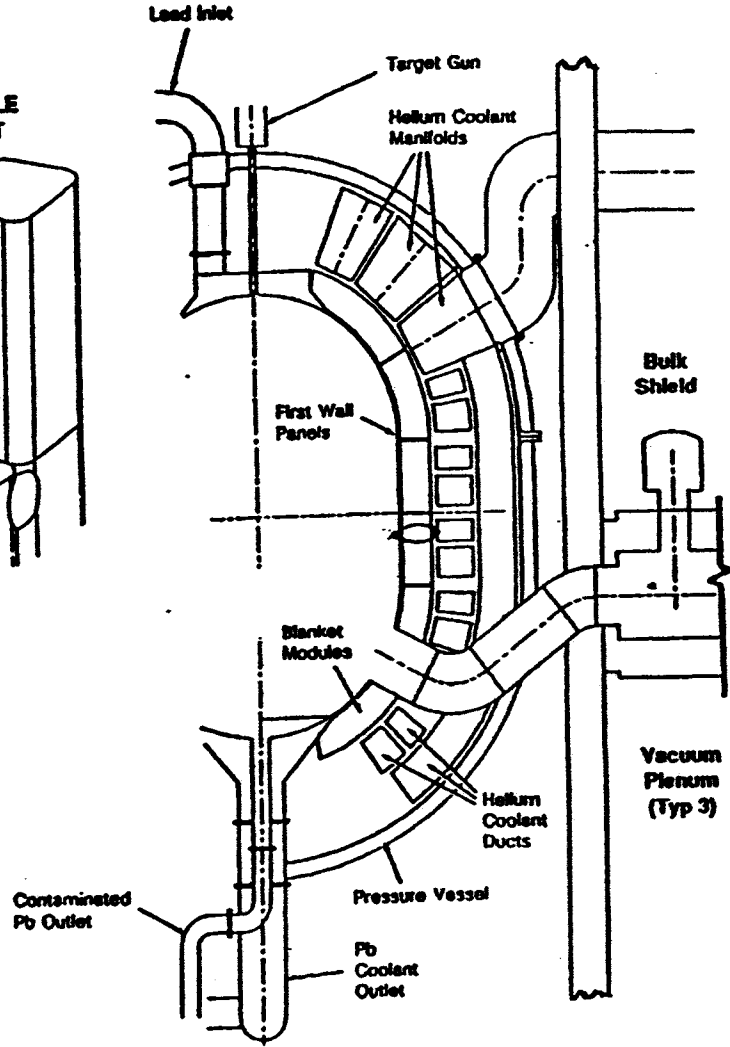
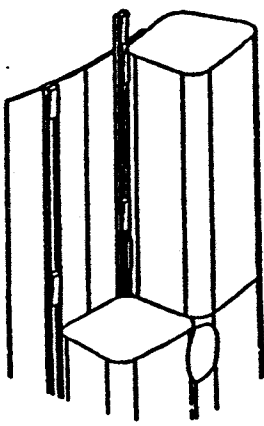
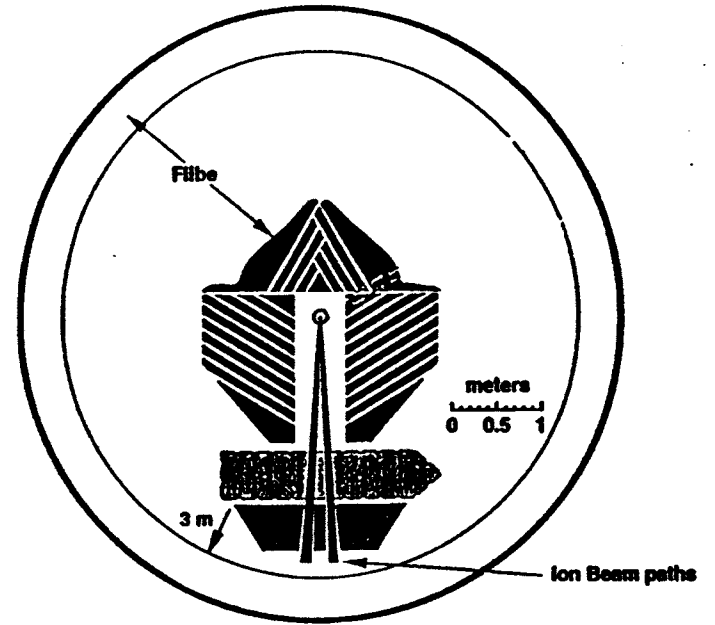
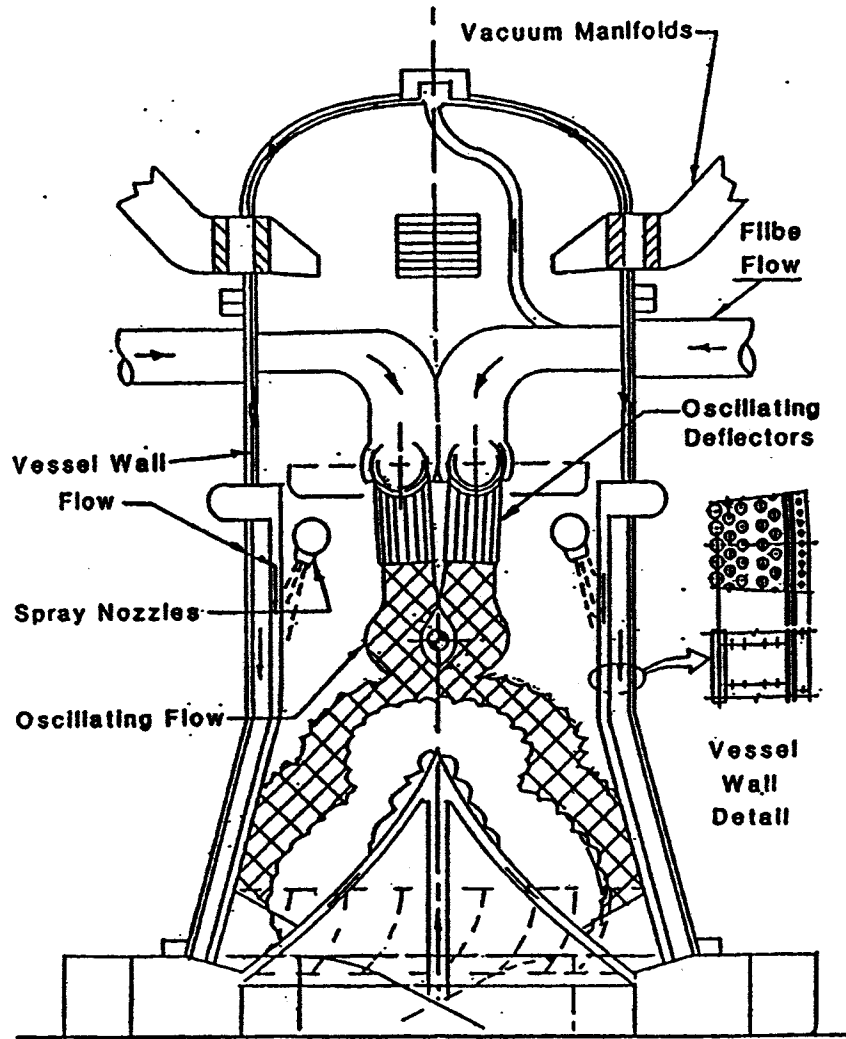

Figure 2.4-9 Schematic of a Blanket Module

10

# Thick Liquid Protection of Chamber Wall



Cross Section through liquid  
Top View

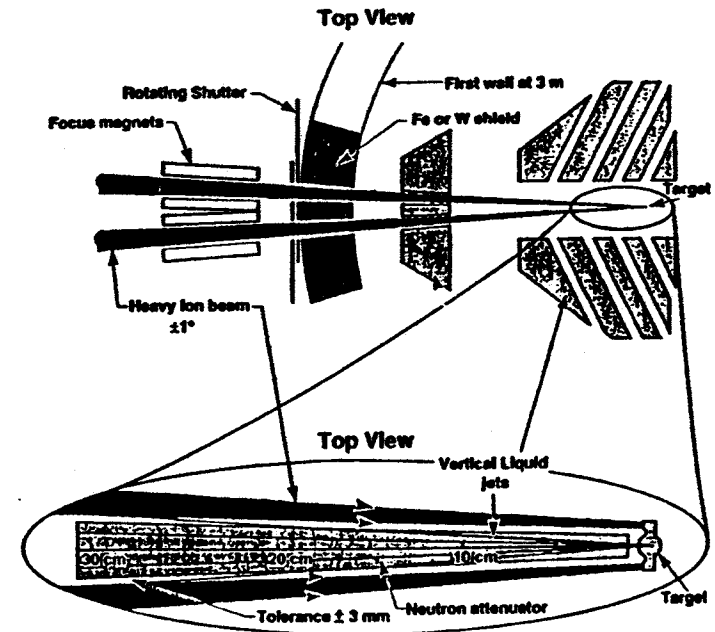

# A liquid "pocket" surrounds the microexplosion and protects the walls from neutron damage



12

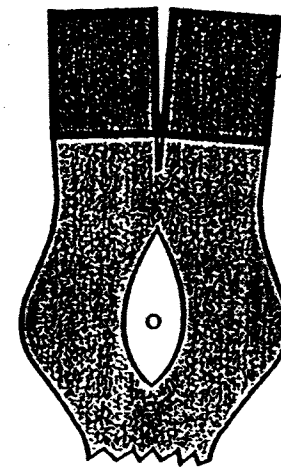
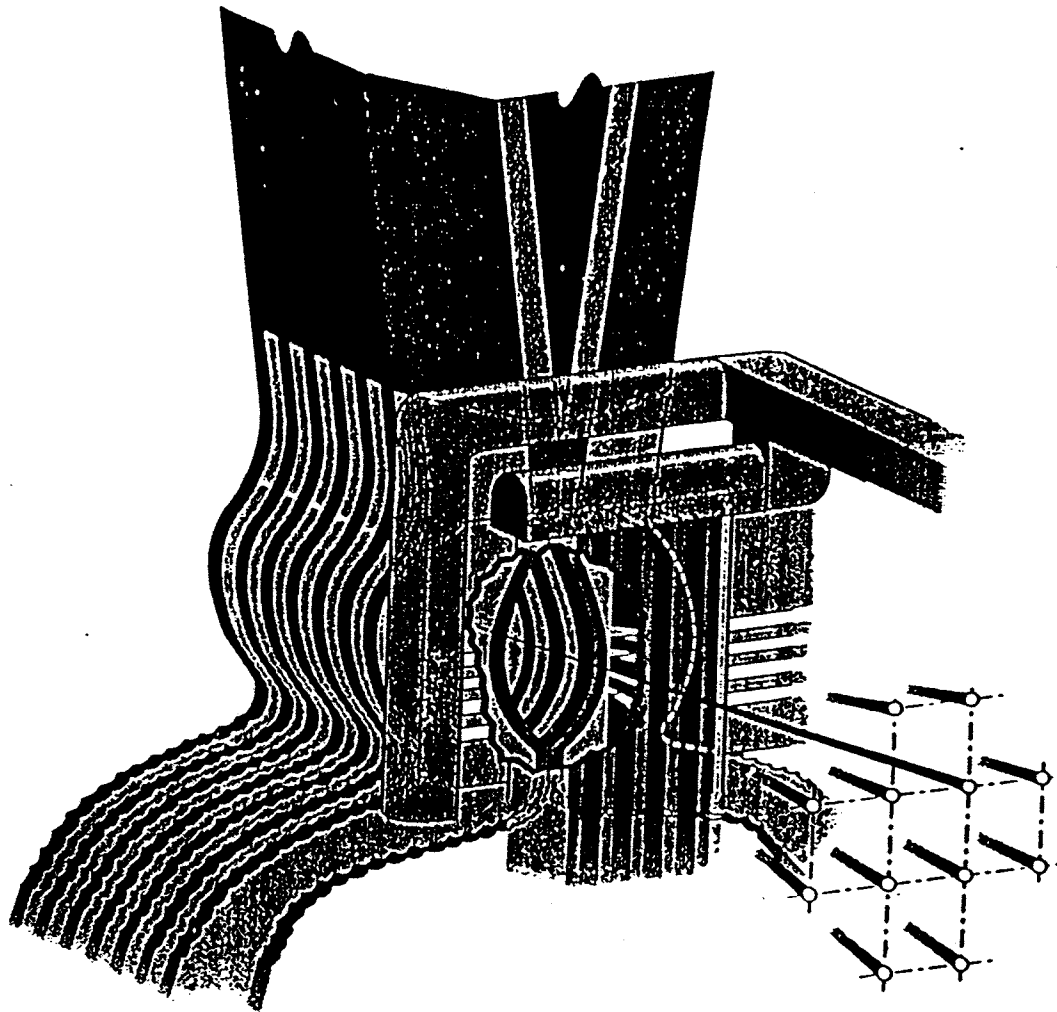

Metal  
nozzles

Jets removed  
Front View

The beam ports are protected from neutron damage

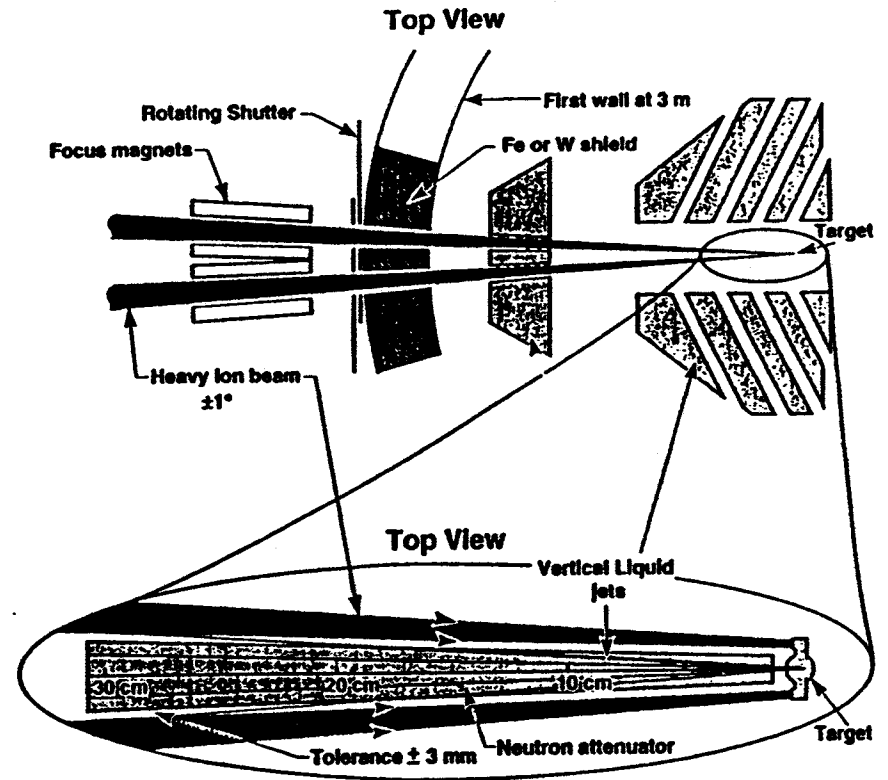
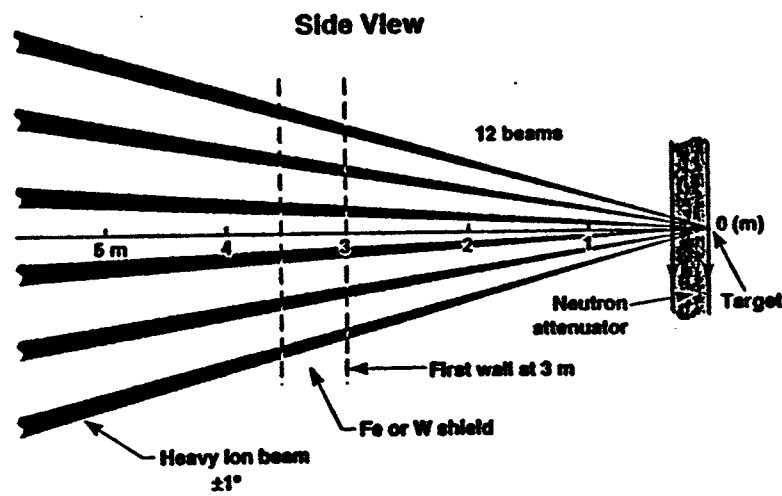

# The jets from a pocket that attenuates neutrons but vents vapor rapidly

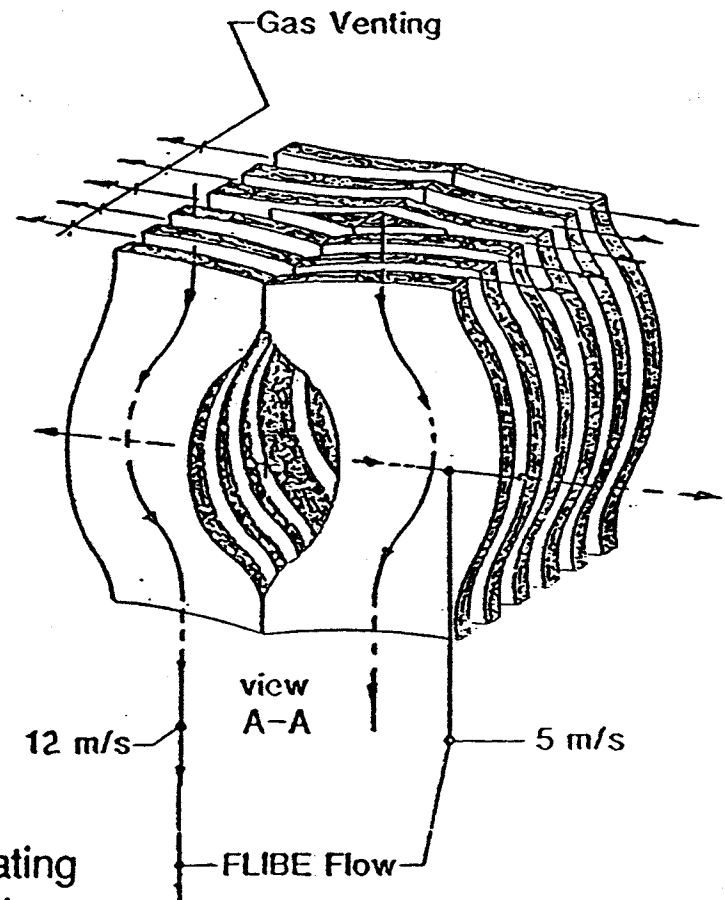
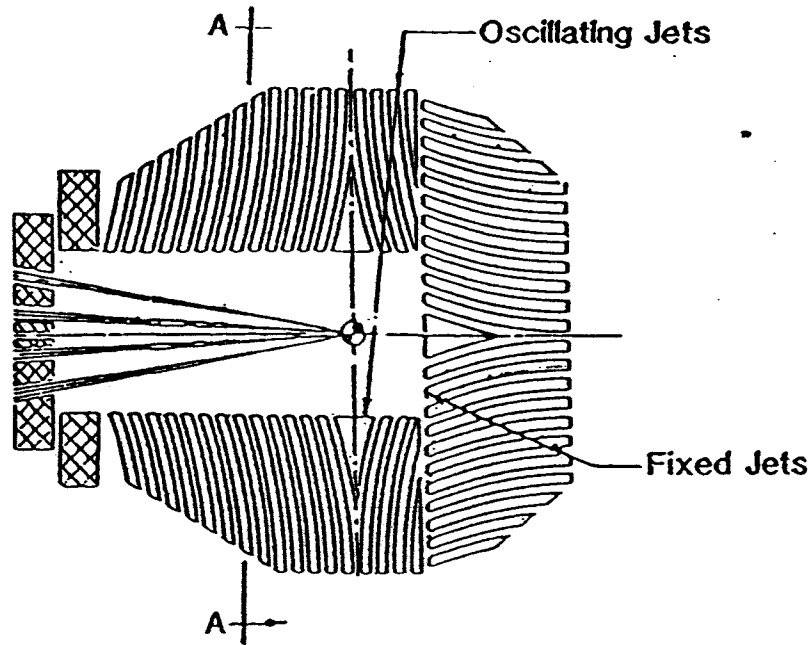

Estimated radial impulse

- 0.5 m/s X-ray Ablation impulse
- 0.5 m/s From gas pressure during venting
- 4.0 m/s Impulse from isochoric neutron heating
- 5.0 m/s Total shot induced outward velocity

17

# The Sequence Shows the Effect of Sweeping the Chamber Clear of Droplets

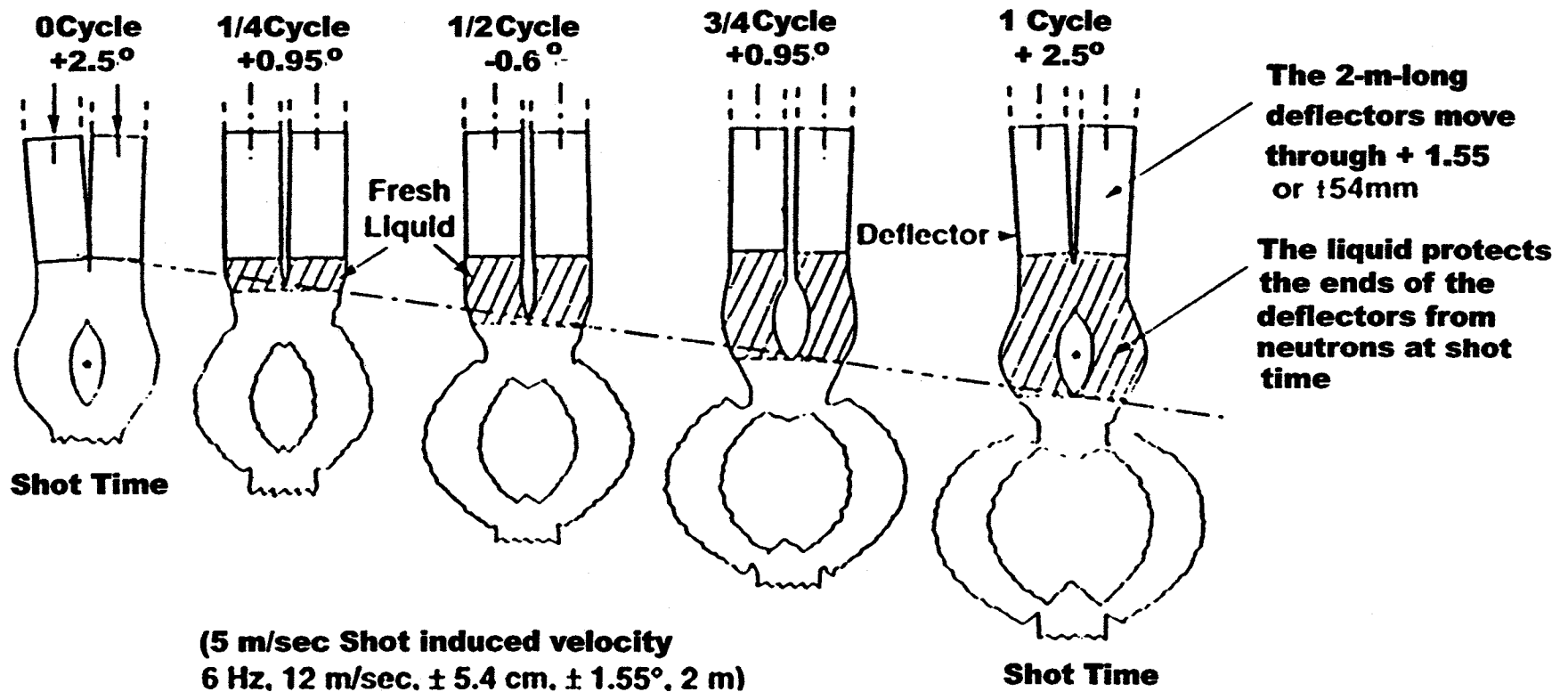

# Inertial fusion power plants can use renewable liquid-protected walls to achieve long life, low activation and low maintenance costs

16

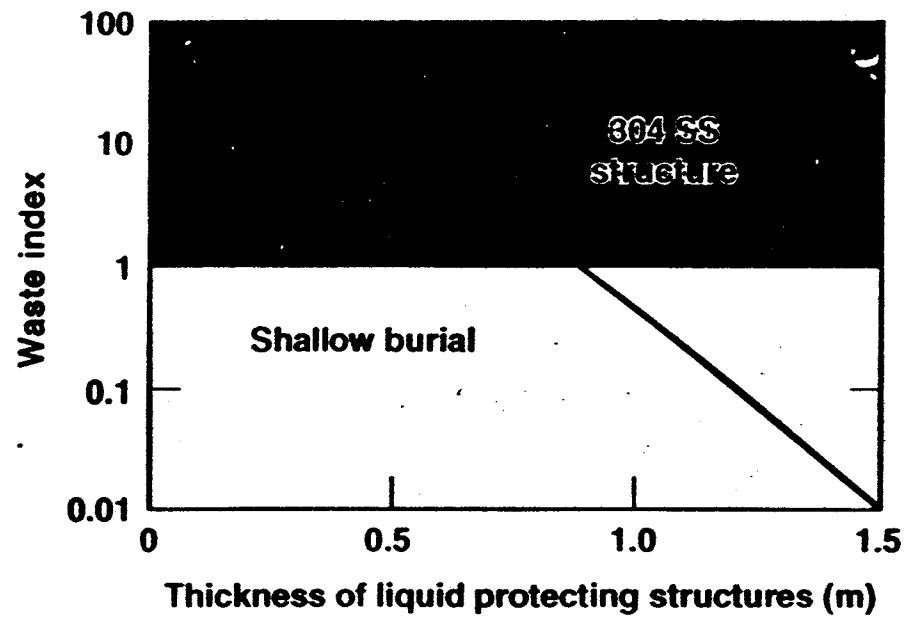
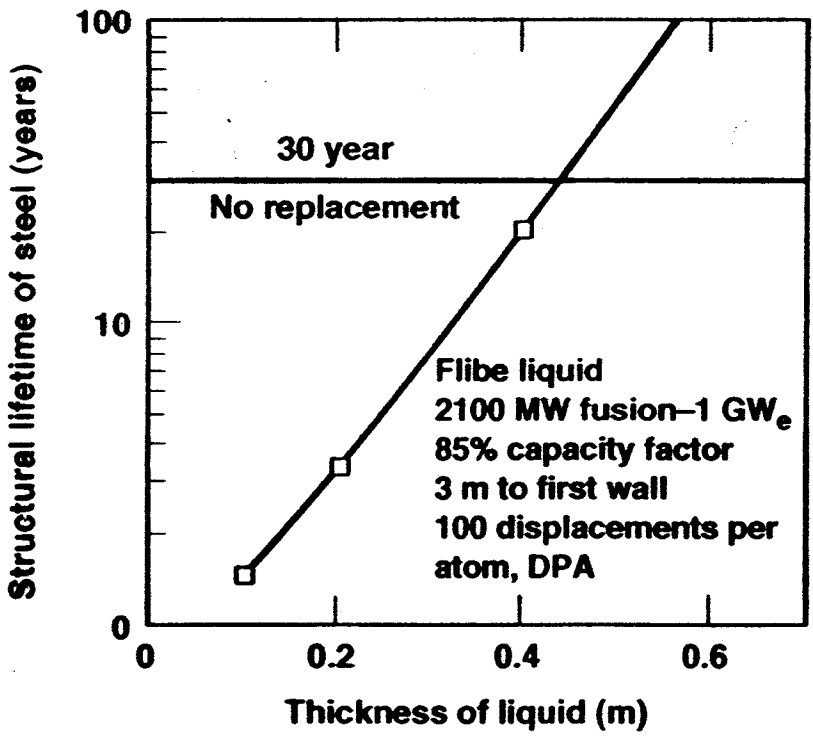



## Profound Implications of Thick Liquid Metal Protection for IFE Development

1. Conventional Stainless Steel would become “low activation material” in IFE solid first wall. It would qualify for shallow land burial.
  - (There is presently no other technically credible approach to achieve this goal in any DT fusion concept).
2. The solid first wall and the remainder of the blanket would have much reduced loading conditions. It would become a “simple technology” that could be built with essentially the current data base.
3. Life-of-the-plant structure even with current structural material.
4. It would almost eliminate the cost, time, and the very large uncertainties associated with new material development.

# The Liquid Wall Protection Offers Opportunity for Challenging “Science” Research

The thick liquid metal protection design uses a curtain of oscillating and stationary molten salt (flibe) sheet jets to protect the reactor chamber solid wall and beam ports. The design concept relies on:

- Generating controlled and precise liquid geometries.
- And condensing ablated vapor on spray droplets, which also sweeps away the droplets rapidly to provide a clean path for target injection and beam transmission.

The current literature is inadequate for predicting the stability of such high velocity (high Reynolds and Weber numbers) jets in vacuum, exposed to turbulent fluctuations and large-scale secondary jets ( $Re = \text{inertia/viscous}$ ,  $We = \text{inertia/surface tension}$ ).

Characteristics of Liquid JET Protection (HYLIFE-II)

Quantity	Flibe	Quantity	Flibe
Jet Reynolds number	$2.43 \times 10^5$	Nozzle oscillation frequency [Hz]	6.0
Jet Weber number	$1.03 \times 10^5$	Nozzle oscillation amplitude [cm]	9.0
Jet thickness [cm]	7.0	Ambient pressure [atm]	~0
Jet width [cm]	100	Fluid temperature [°C]	660
Jet aspect ratio	14.3	Fluid density [ $\text{kg/m}^3$ ]	1963
Jet fall distance [m]	2.0	Fluid viscosity [ $\text{kg/m} \cdot \text{s}$ ]	$6.78 \times 10^{-3}$
Jet velocity [m/s]	12.0	Fluid surface tension [N/m]	0.193
Jet volumetric flow rate [ $\text{m}^3/\text{s}$ ]	0.84		
Jet dynamic pressure ( $\rho U_j^2$ ) [Pa]	$2.83 \times 10^5$		

18

## Isochoric Heating and Outward Forces

- The thick liquid wall protection has to also serve as the blanket (partial) with heat removal and tritium breeding.
- The liquid blanket is subjected to forces associated with X-ray ablation, gas pressure (from drag), and shear (skin drag) that impart an outward radial motion toward the vessel wall.
- These contributions may be augmented further by the net effect of break up (fracture of the liquid) following neutron-induced isochoric heating of the blanket [Isochoric, constant-volume heating is the intense, instantaneous, volumetric heating that occurs as the fusion neutrons are absorbed in the liquid, generating internal pressures of hundreds of atmospheres].
- One estimate is that the liquid blanket will receive an average velocity of  $\sim 7\text{m/s}$ , which would result in impacting the bottom of the wall with low pressure. But many complex phenomena are involved and can not now be predicted with confidence.

19

## Issues To Resolve For Thick Liquid Metal Protection

1. Hydrodynamic Stability of high Reynolds number jets in vacuum exposed to turbulent fluctuations and large scale secondary flows
2. To show that the condensation of the evaporated liquid is quick enough to permit the required pulse (repetition) rate without interfering with the passage of the beams to the target
3. To show that the incoming liquid clears the splashed liquid from a prior micro-explosion to not interfere with the target injection and ion beam propagation for the next shot
4. Show that the liquid jet configurations can be made to meet the required conditions (including protection of beam ports, particularly focusing magnets)
5. Reliability of metal nozzles and mechanical moving parts, including fatigue and vibration
6. Understand Isochoric Heating and Gas Venting to predict net outward momentum
7. Show that tritium self sufficiency can still be satisfied in a system that uses this concept

## Chamber Clearing at IFE Repetition Rate

- IFE Power Plants require a repetition rate:
  - ~ 3 - 10 pulses per second.
- Following each pellet explosion the chamber fills with target debris and material evaporated, or otherwise ejected from the cavity surfaces.
- This material must be removed from the cavity before the next target/beam are injected.
  - Recondense Condensable Gases into cavity surfaces.
  - Pump non-condensable gases through large ducts.
- Issues
  - A) Evacuation Requirements (base pressure).
    - depend on propagation limits for both target and driver energy
  - B) Ability to clear the chamber to the required base pressure during the time available between shots.
    - Highly Dependent on the Specific Wall Protection Scheme.

## Other Chamber Issues (In addition to Wall Protection and Chamber Clearing)

- Tritium Self Sufficiency in a Practical IFE System.
- Adequate Radiation Shielding of All Components.
- Pulsed Radiation Damage and Thermomechanical Response of first wall/blankets, particularly for concepts without thick liquid metal protection.

### Observations

- These issues are important and could be critical.
- Some aspects will have to be addressed as part of Wall Protection Research.
- The severity and specifics of these issues will greatly depend on the selected wall protection scheme.

# The Key Issue of Final Laser Optics Received Attention in Design Studies

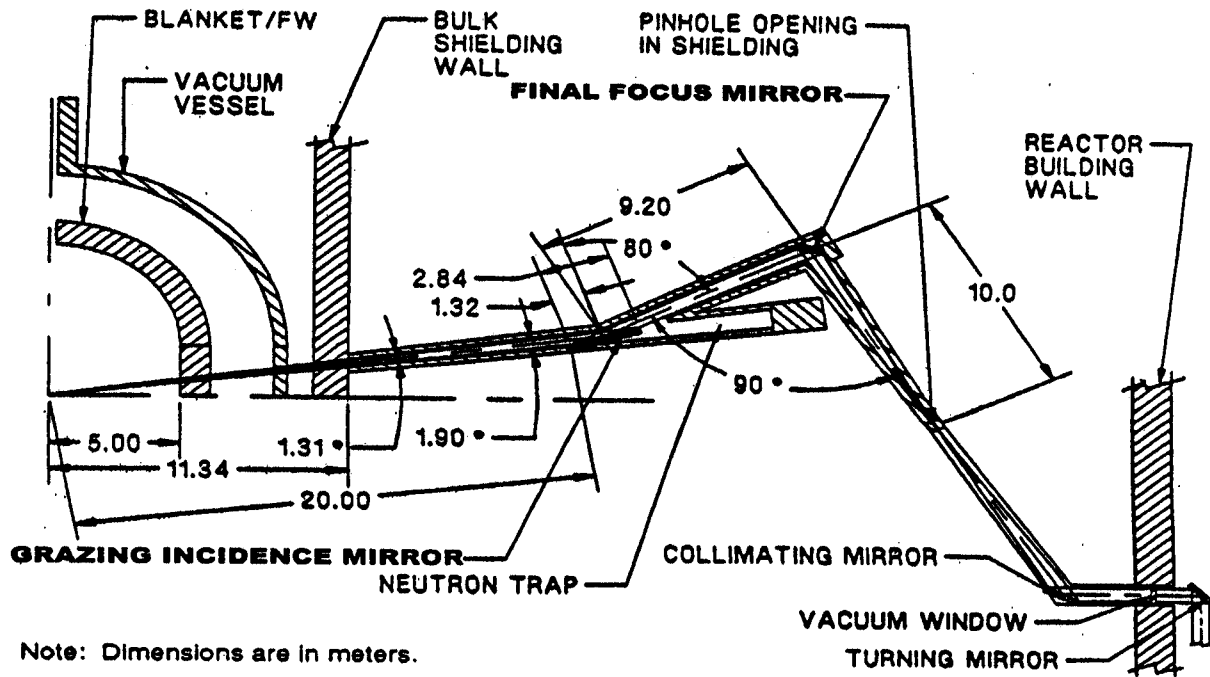

**PROMETHEUS-L FINAL OPTICS CONFIGURATION**

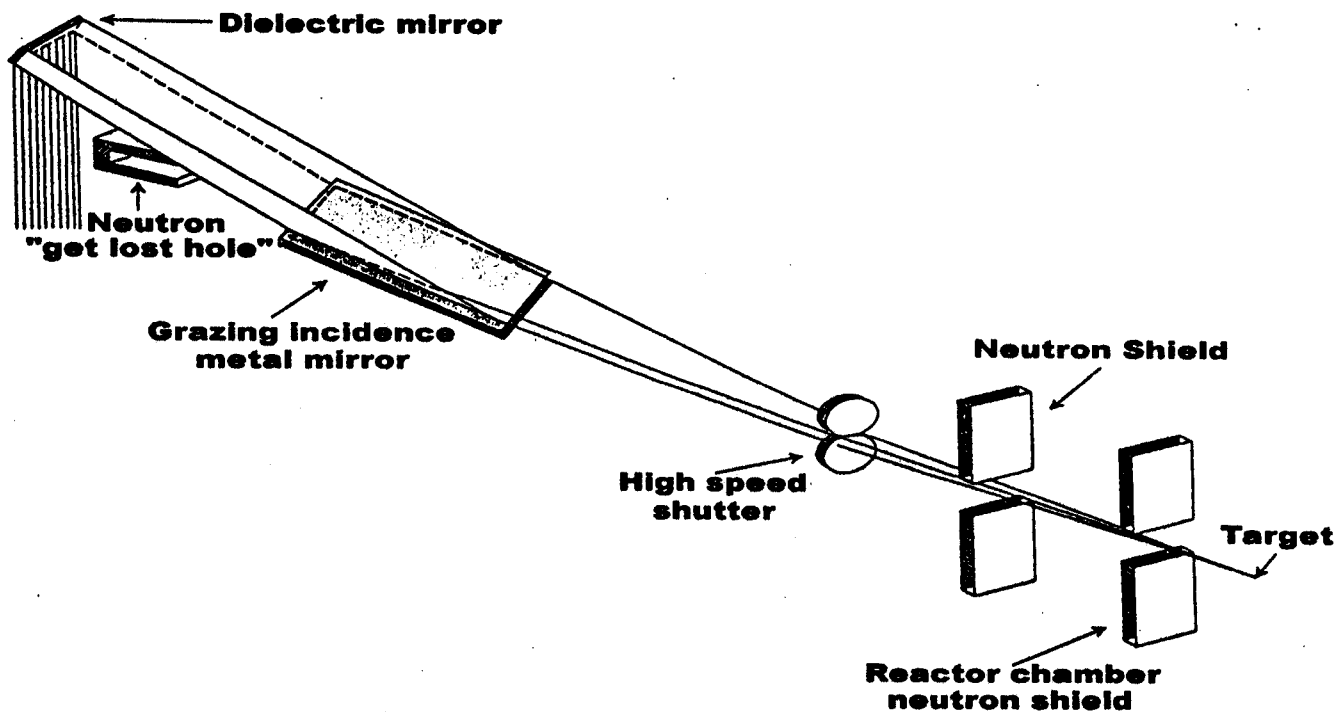

**SOMBRERO FOCUSING SCHEME USING GRAZING INCIDENT METAL MIRRORS**

# Key Issues of Liquid Chamber Wall Protection Schemes for IFE

---

“Chamber Wall Protection is an excellent example of how a very serious technical Problem has been turned into a Potential Opportunity through Innovative design solutions that Promise to give IFE unique advantages and radically eliminate long-term activation of conventional structural materials.” FEAC report- July, 1996

**Thick Liquid Wall Protection Schemes**

**Thin Liquid Wall Protection Schemes**

**Available Data Base and Near-Term Experimental Focus**

Alice Ying

UCLA

Oct. 30, 1996

24



# Evolution of Thick Liquid Wall Protection Schemes

---

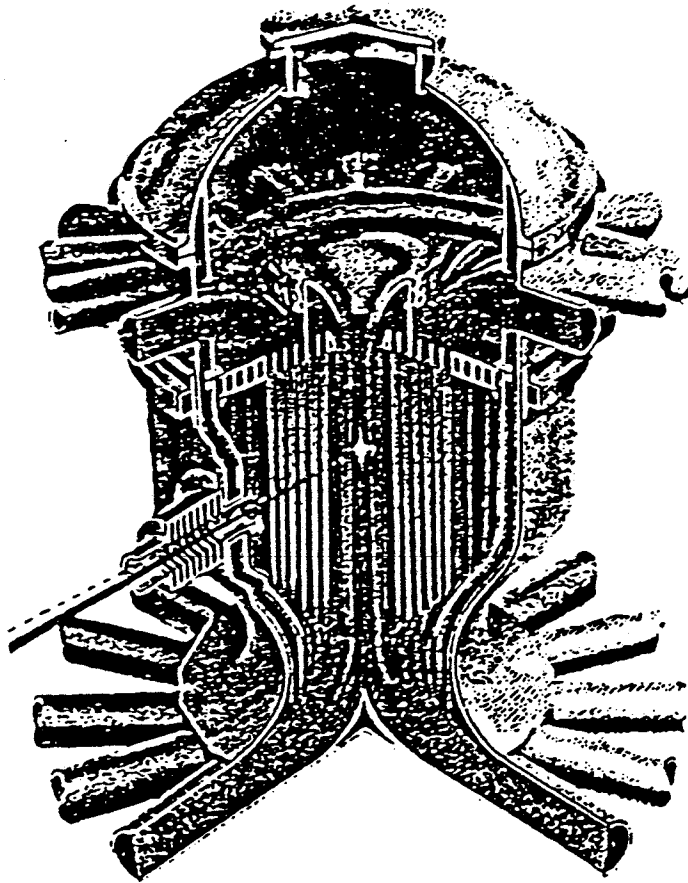
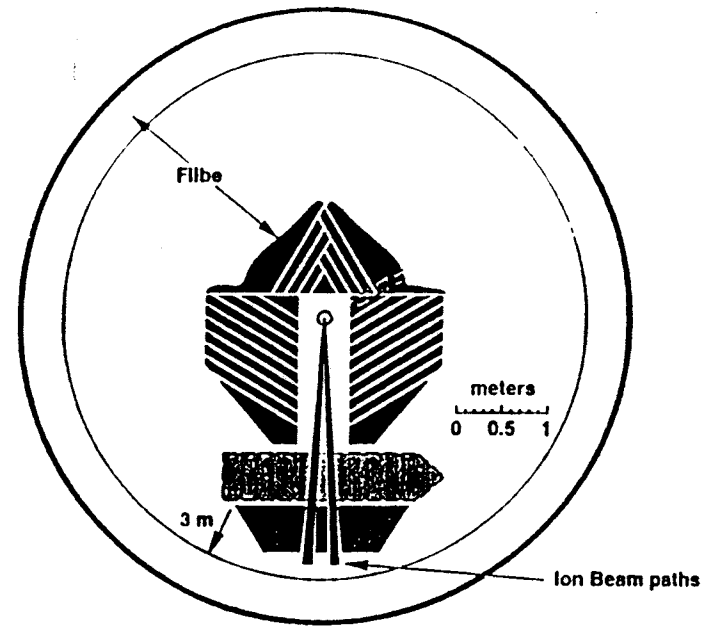
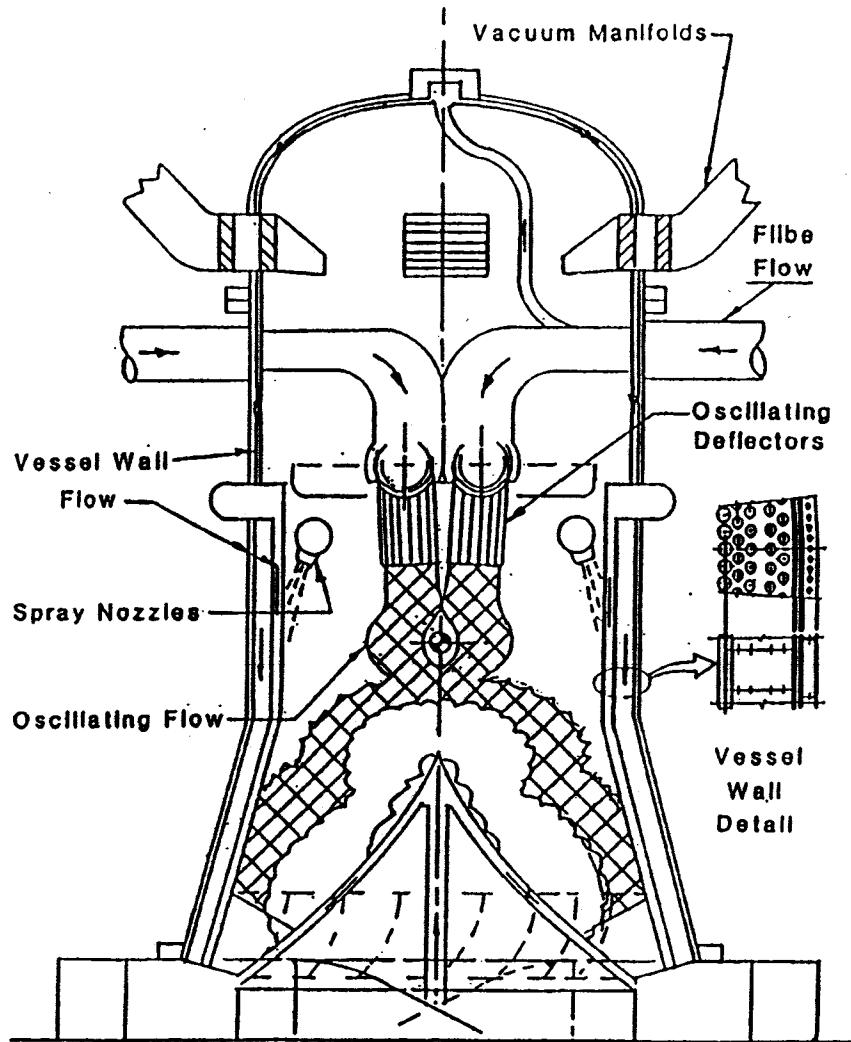

Fig. 4. HYLIFE-I used steady flow.

- Liquid Lithium Steady Flow: HYLIFE-I (Burke, 1974; Blink, 1985)
  - Long jet reformation time (1.5 Hz repetition rate)
  - Lithium fire and large tritium inventory
- ▶ Liquid Flibe Steady Flow: HYLIFE-II (Moir, 1989)
  - Eliminate lithium fire
  - Low repetition rate; multiple chambers required
- ▶ Liquid Flibe Pulsed Flow and Liquid Flibe Oscillating Flow: HYLIFE-II (1990)

25

# Thick Liquid Protection of Chamber Wall



Cross Section through liquid  
Top View

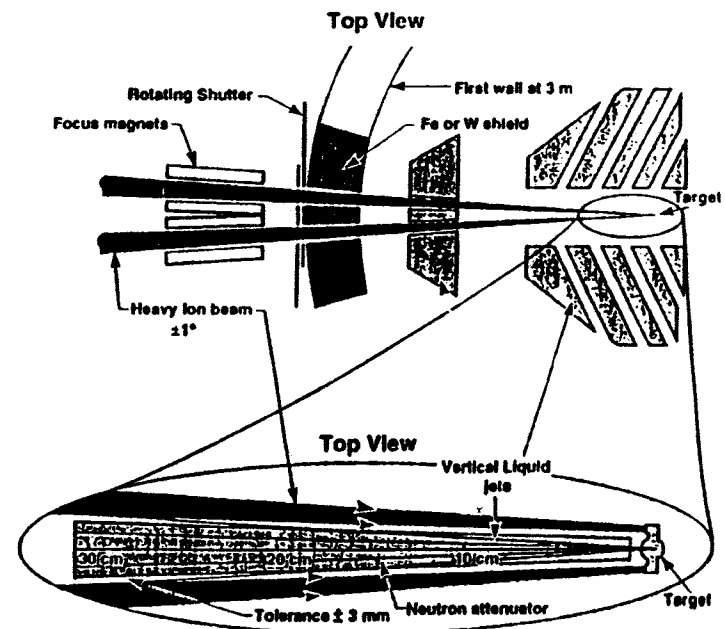

26

# Alternative Thick Liquid Wall Protection Schemes

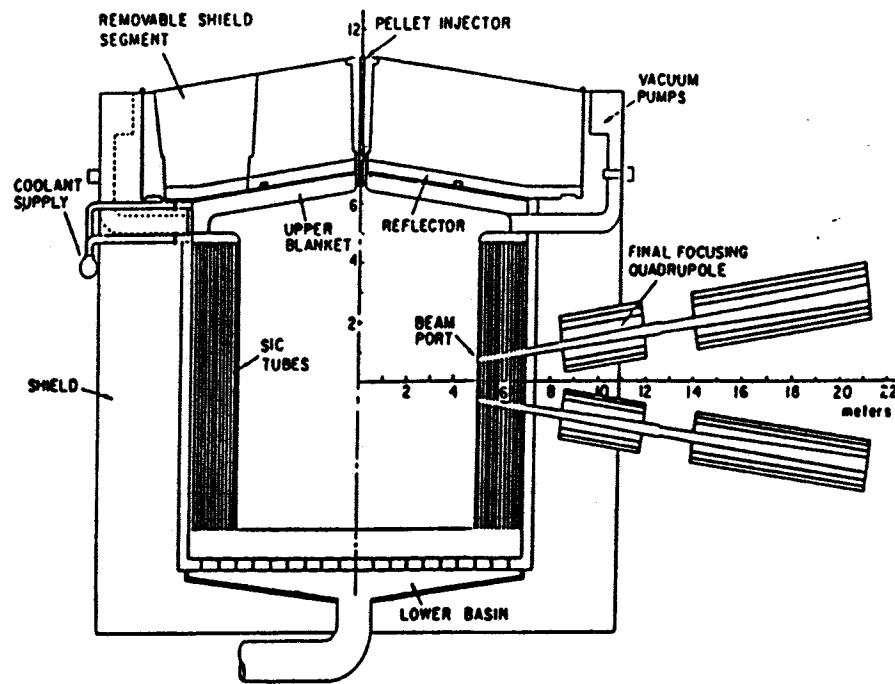

Fig. 1. HIBALL: A heavy ion beam driven, LiPb protected reactor.

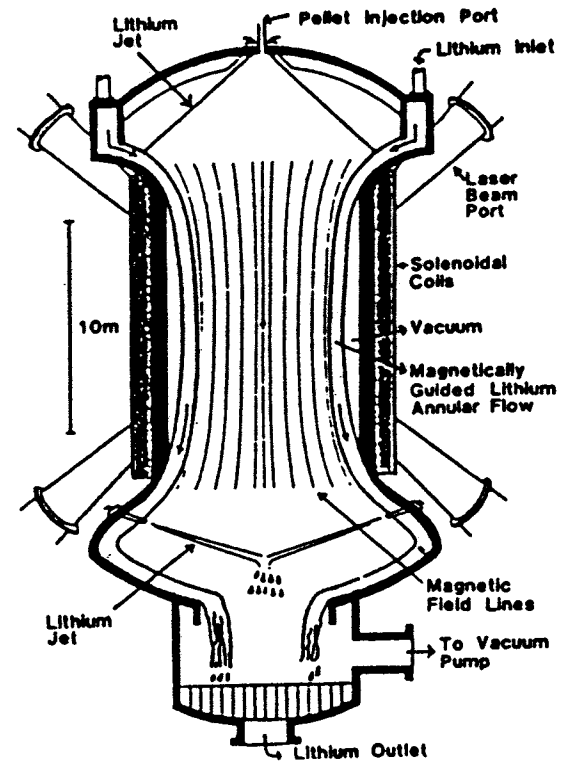
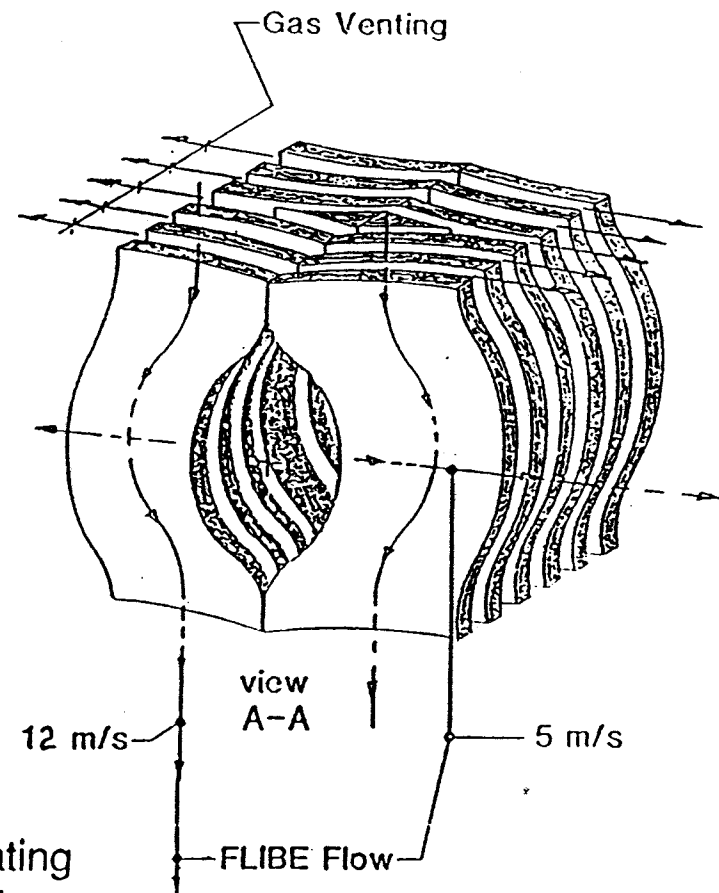
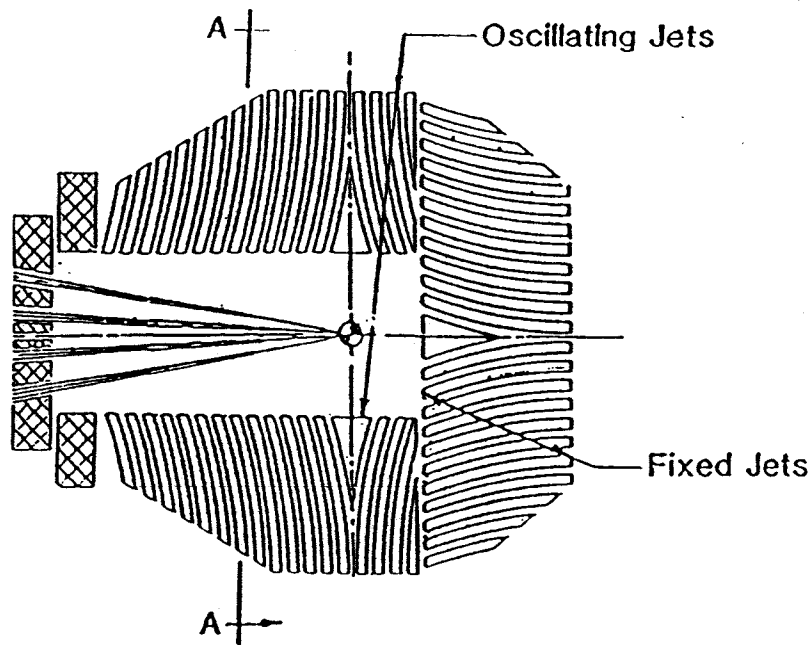

Fig. 2. An ICF reactor concept with magnetically guided Li flow, SENRI-IA.

# The jets from a pocket that attenuates neutrons but vents vapor rapidly



Estimated radial impulse

- 0.5 m/s X-ray Ablation impulse
- 0.5 m/s From gas pressure during venting
- 4.0 m/s Impulse from isochoric neutron heating
- 5.0 m/s Total shot induced outward velocity

# The beam ports are protected from neutron damage

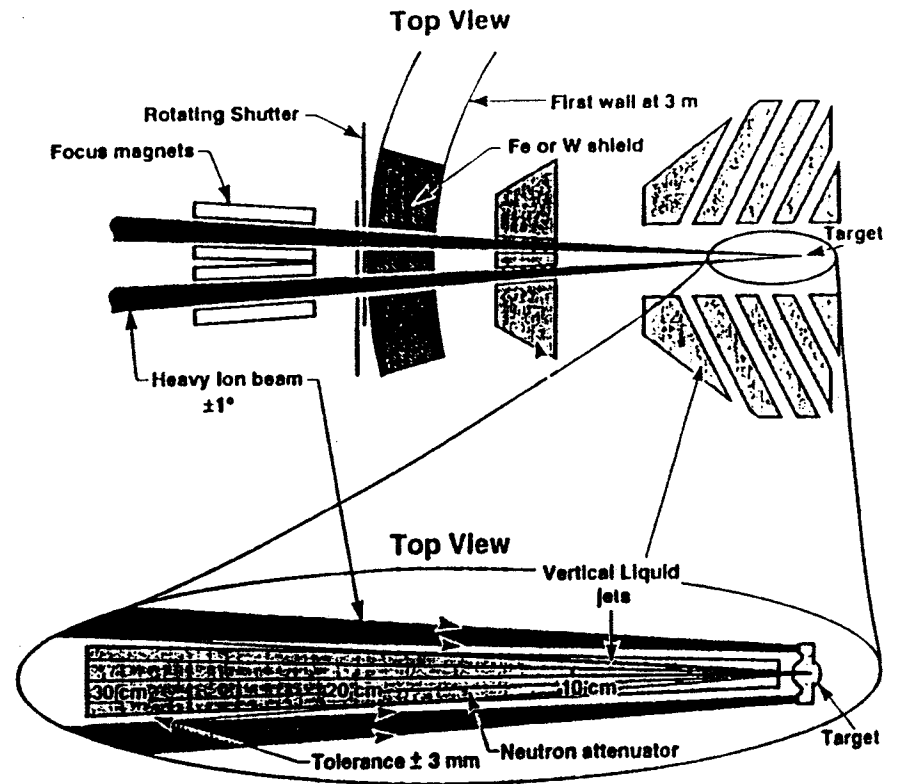
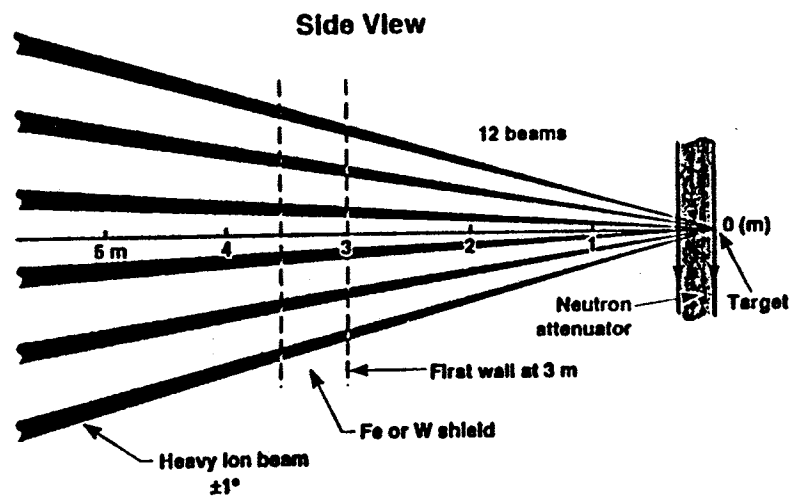

29

## Issues To Resolve For Thick Liquid Metal Protection

1. Hydrodynamic Stability of high Reynolds number jets in vacuum exposed to turbulent fluctuations and large scale secondary flows
2. To show that the condensation of the evaporated liquid is quick enough to permit the required pulse (repetition) rate without interfering with the passage of the beams to the target
3. To show that the incoming liquid clears the splashed liquid from a prior micro-explosion to not interfere with the target injection and ion beam propagation for the next shot
4. Show that the liquid jet configurations can be made to meet the required conditions (including protection of beam ports, particularly focusing magnets)
5. Reliability of metal nozzles and mechanical moving parts, including fatigue and vibration
6. Understand Isochoric Heating and Gas Venting to predict net outward momentum
7. Show that tritium self sufficiency can still be satisfied in a system that uses this concept

80

## Isochoric Heating and Outward Forces

- The thick liquid wall protection has to also serve as the blanket (partial) with heat removal and tritium breeding.
- The liquid blanket is subjected to forces associated with X-ray ablation, gas pressure (from drag), and shear (skin drag) that impart an outward radial motion toward the vessel wall.
- These contributions may be augmented further by the net effect of break up (fracture of the liquid) following neutron-induced isochoric heating of the blanket [Isochoric, constant-volume heating is the intense, instantaneous, volumetric heating that occurs as the fusion neutrons are absorbed in the liquid, generating internal pressures of hundreds of atmospheres].
- One estimate is that the liquid blanket will receive an average velocity of  $\sim 7\text{m/s}$ , which would result in impacting the bottom of the wall with low pressure. But many complex phenomena are involved and can not now be predicted with confidence.

# Thin Liquid Protection of Chamber Wall

FIRST WALL BLANKET MODULE ARRANGEMENT

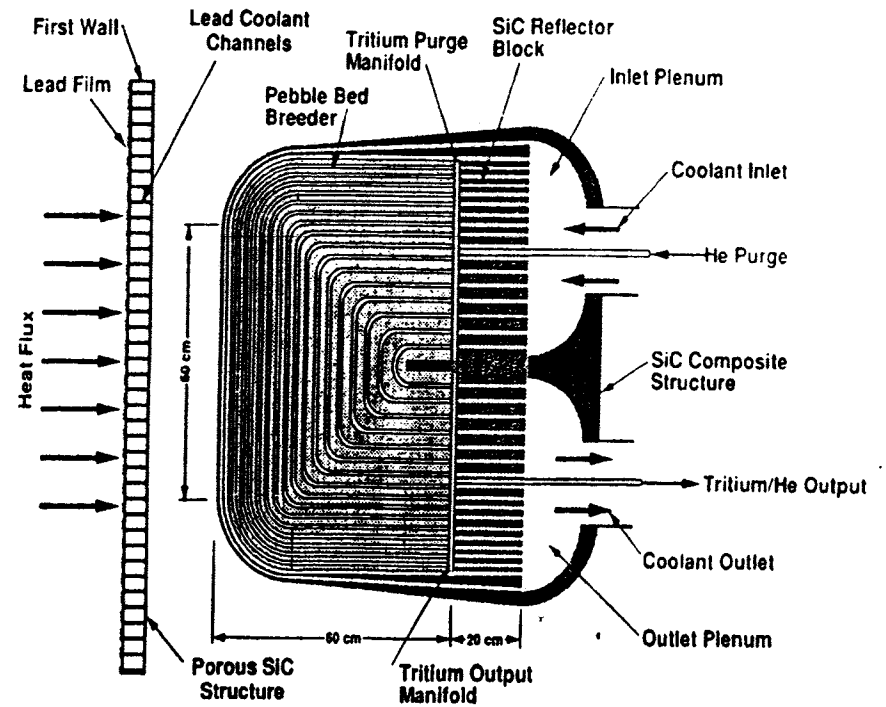
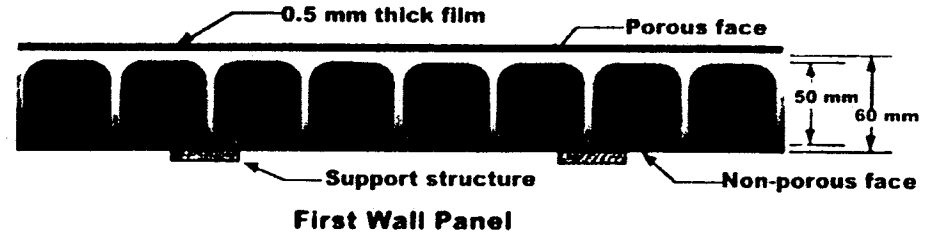
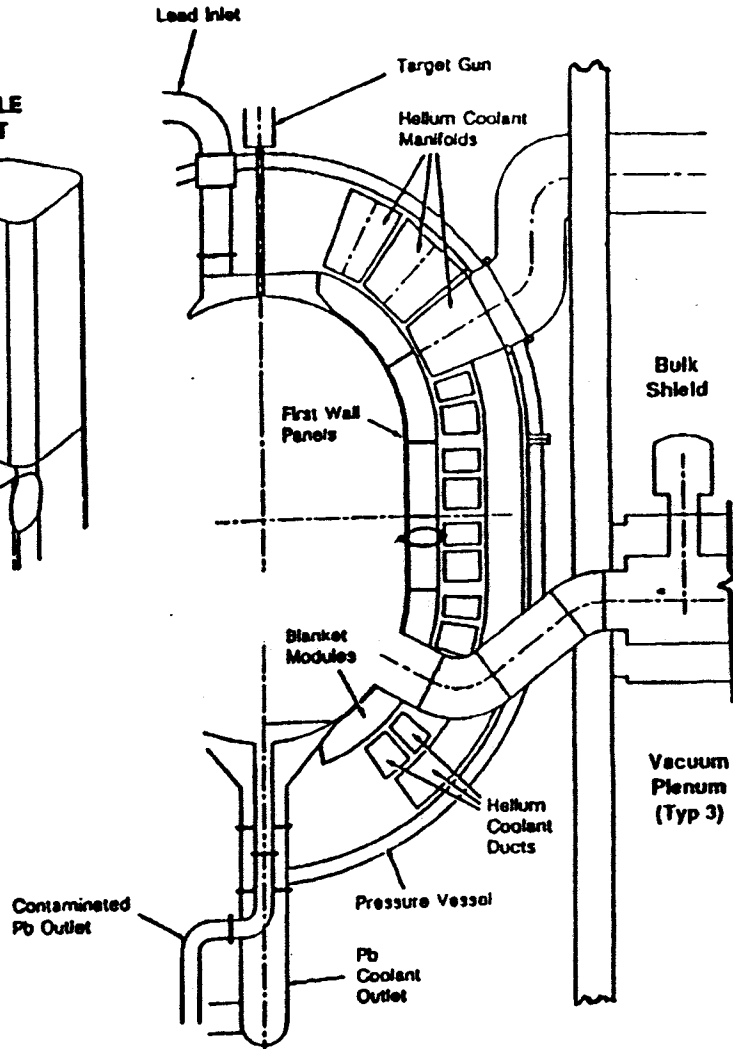
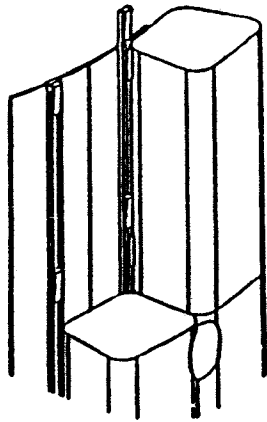
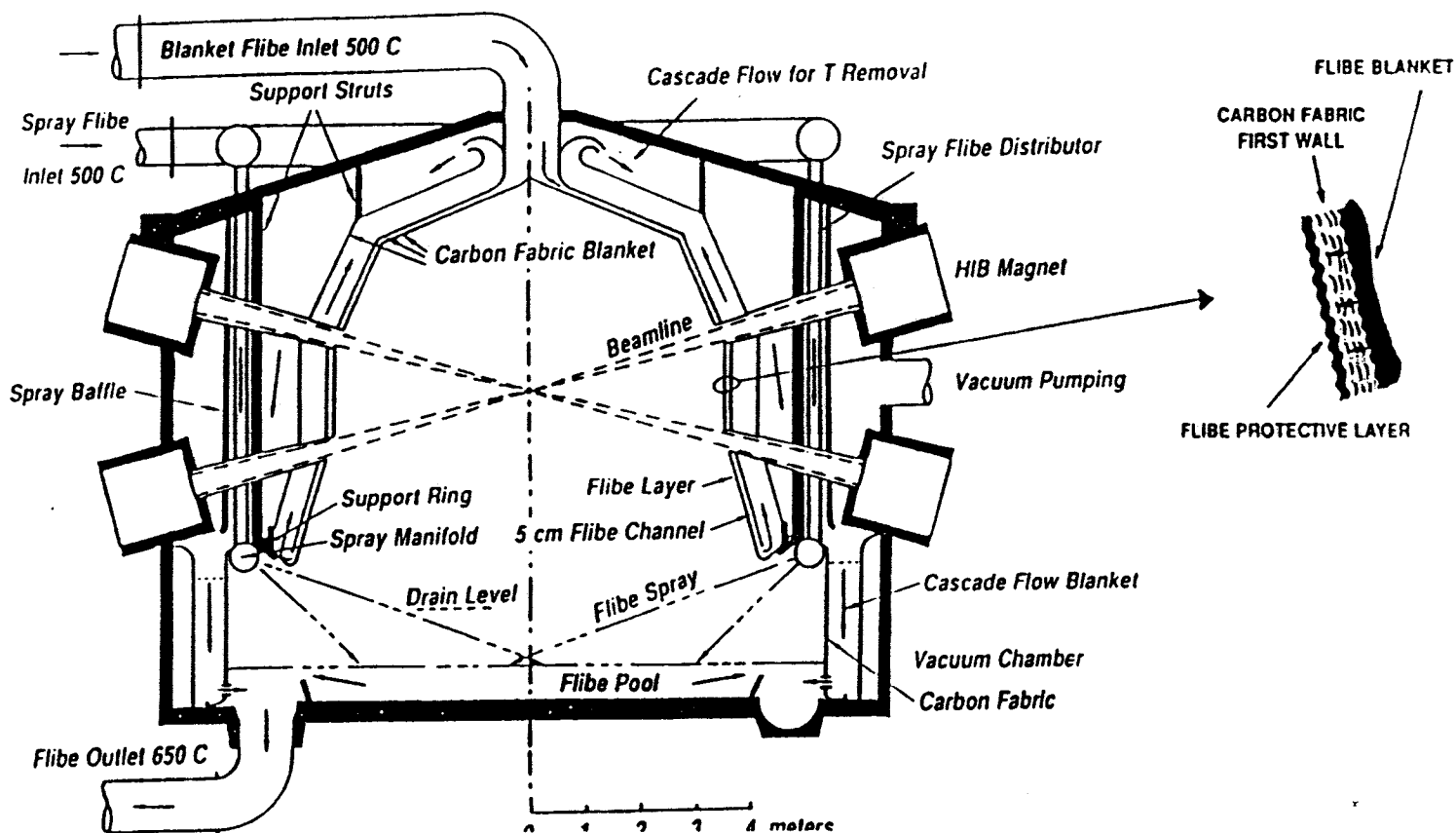

Figure 2.4-9 Schematic of a Blanket Module

32



# Osiris - Thin Liquid Film Protection of Chamber Wall



# Issues to Resolve for Thin Liquid Metal Wall Protection

---

- Flow around geometric perturbations (such as beam penetrations)
- Protection of inverted surfaces
- Film feeding and thickness control
- Blast effects on film protection thickness and stability
  - soft x-ray ablation impulse
  - isochoric heating relaxation
  - cavity gas shock relaxation
- Compatibility and wetting of liquid/solid combinations
- Cavity clearing and vapor condensation

## Chamber Clearing at IFE Repetition Rate

- IFE Power Plants require a repetition rate:
  - ~ 3 - 10 pulses per second.
- Following each pellet explosion the chamber fills with target debris and material evaporated, or otherwise ejected from the cavity surfaces.
- This material must be removed from the cavity before the next target/beam are injected.
  - Recondense Condensable Gases into cavity surfaces.
  - Pump non-condensable gases through large ducts.
- Issues
  - A) Evacuation Requirements (base pressure).
    - depend on propagation limits for both target and driver energy
  - B) Ability to clear the chamber to the required base pressure during the time available between shots.
    - Highly Dependent on the Specific Wall Protection Scheme.

58

# Summary of Available Data Base Relevant to IFE Liquid Wall Protection Schemes

---

- Small scale laboratory experiments have been conducted for:
  - Annular jet (1981)
  - Cylindrical jet subjected to transverse vibrations (1981)
  - Cylindrical jet (1996)

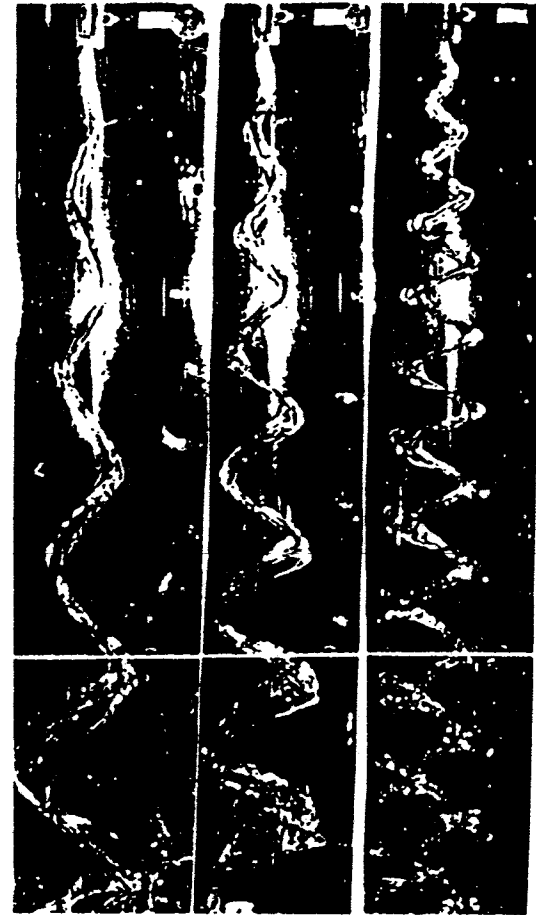

Fig. 11 Edge views of the sheet jets from Nozzle B ( $h_0 = 3.94$  mm,  $U_0 = 2.05$  m/s,  $A_0 = 1.0$  mm,  $p_0 = 1.0$  atm) for three nozzle forcing frequencies: 20, 30, and 50 Hz (going from left to right)

36

# Water Experiments are Difficult to Extrapolate: Flashing due to Water High Vapor Pressure Results in a Unfavorable Jet Configuration

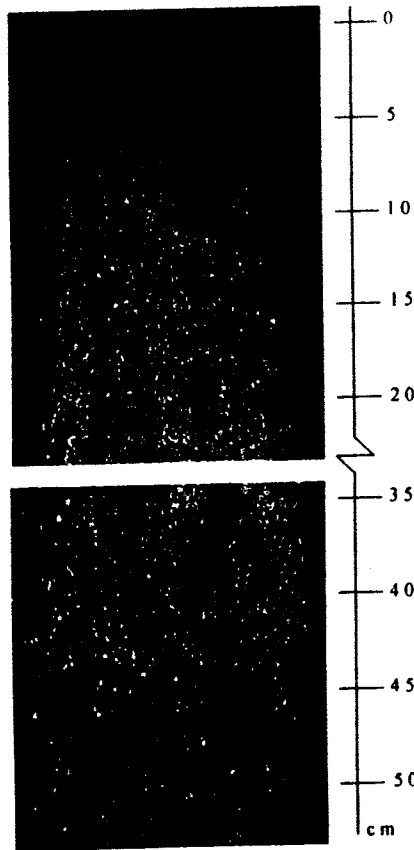
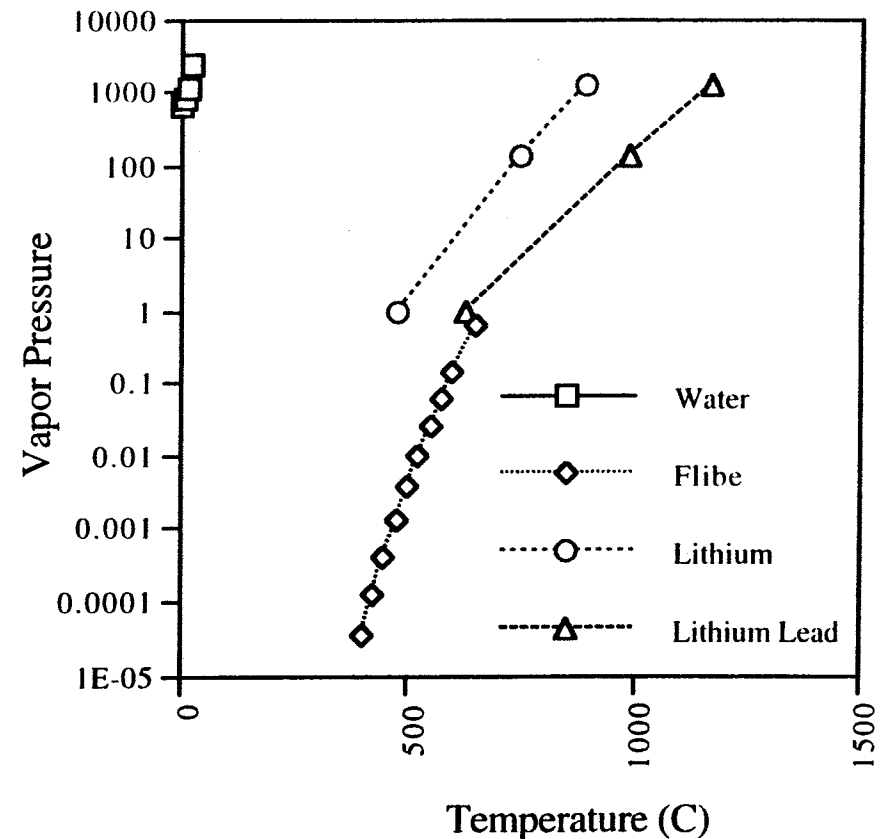

Figure 3: Cylindrical water jet in vacuum,  $Re=9 \times 10^5$ ;  
 $We=1.1 \times 10^5$



UCLA is proposing liquid metal experiments, which are more relevant

# The UCLA Program on IFE is Focused on the Challenging Scientific Research Issues in Liquid Wall Protection

---

- Our planned near term small scale laboratory studies focus on scientific feasibility explorations:
  - Thick liquid jet configurations
  - Film flow stability
  - Vapor condensation phenomena
- Our experiment planning effort is carefully addressing the engineering scaling issues in order to conduct cost-effective, highly relevant experiments

---

# Thick Jet and Thin Film Modeling and Experiments at UCLA

Neil Morley  
Alice Ying  
Mohamed Abdou  
Alexander Gaizer

1. Thick Jet and Thin Film Critical Issues
  2. Modeling of Thin Film Protection Scheme
  3. Current Research Effort
    - a. Compressible Modeling
    - b. Experimental Development
    - c. Facilities
  4. Summary
- 

39

# Designs Using Thin Liquid Film Cavity Protection

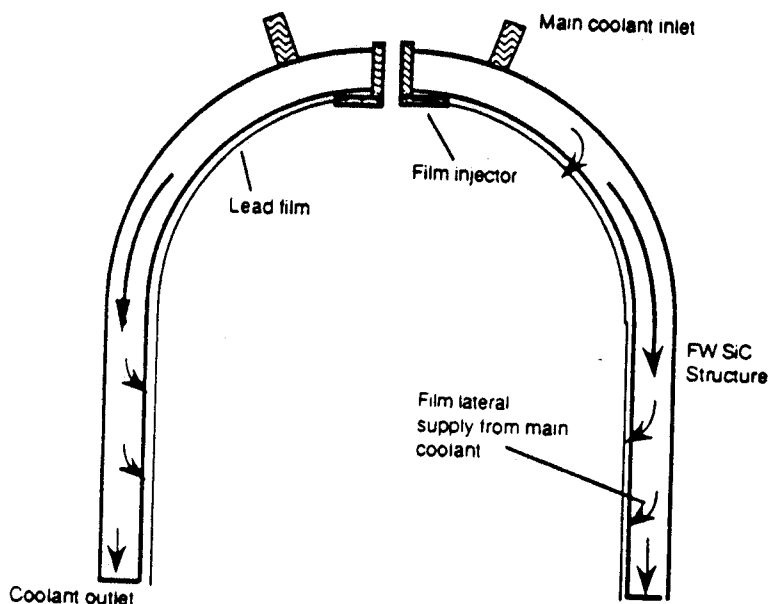

## PROMETHEUS

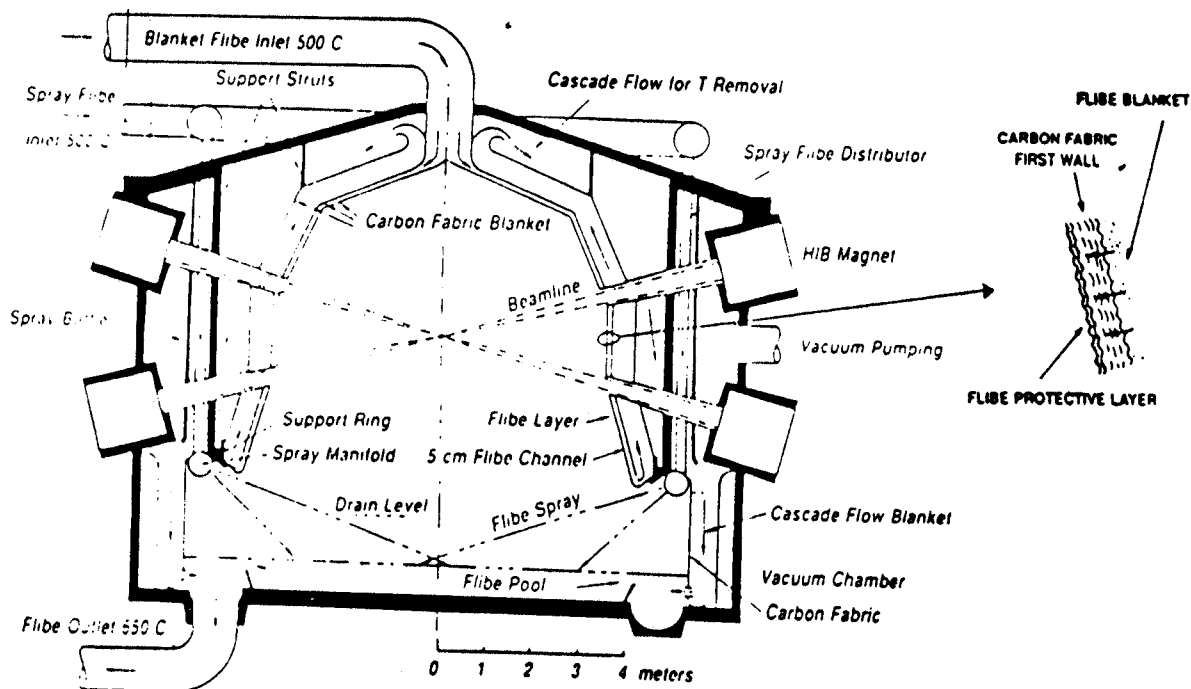

## OSIRUS



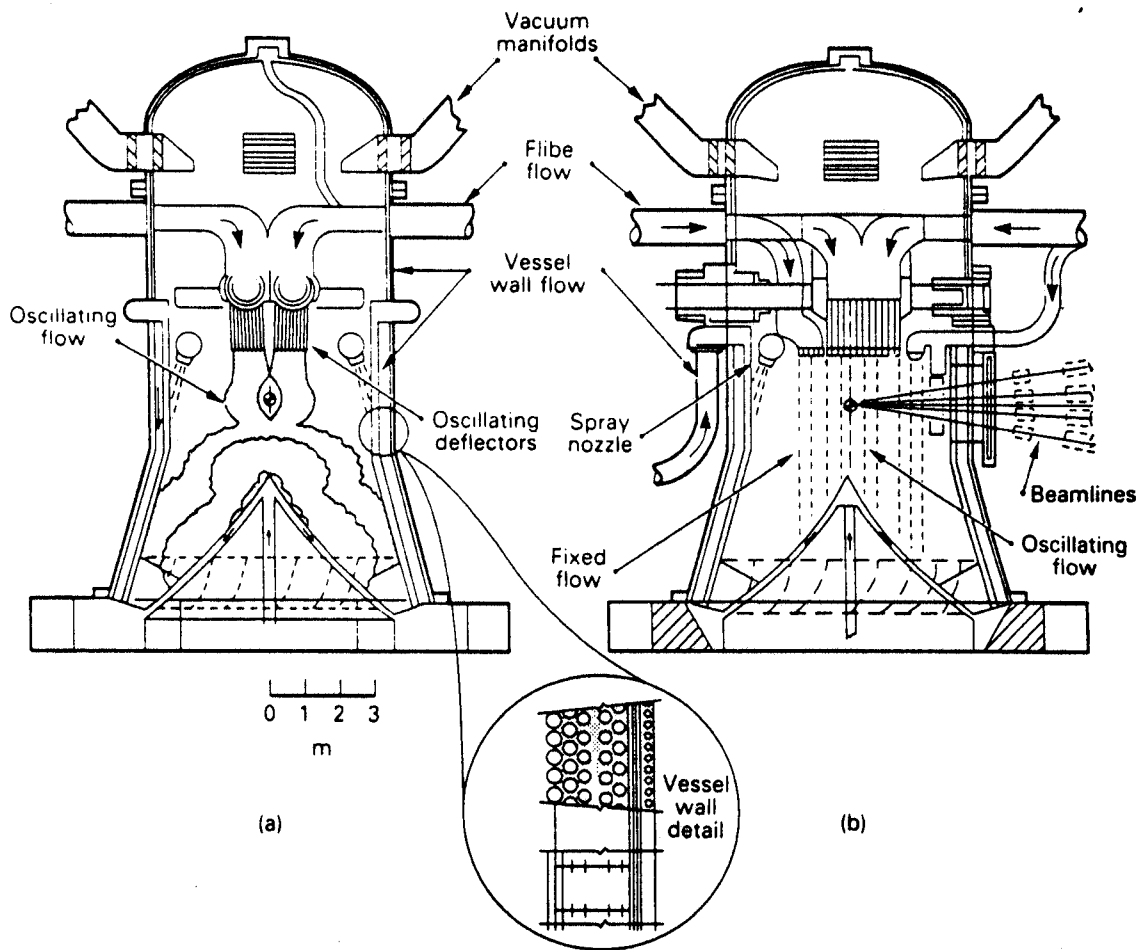

Fig. 2. HYLIFE-II reaction chamber. Liquid Flibe, formed into a "pocket" (i.e., the central cavity in the jet array) by oscillating nozzles, protects the chamber walls. View (b) is rotated 90 deg from view (a).

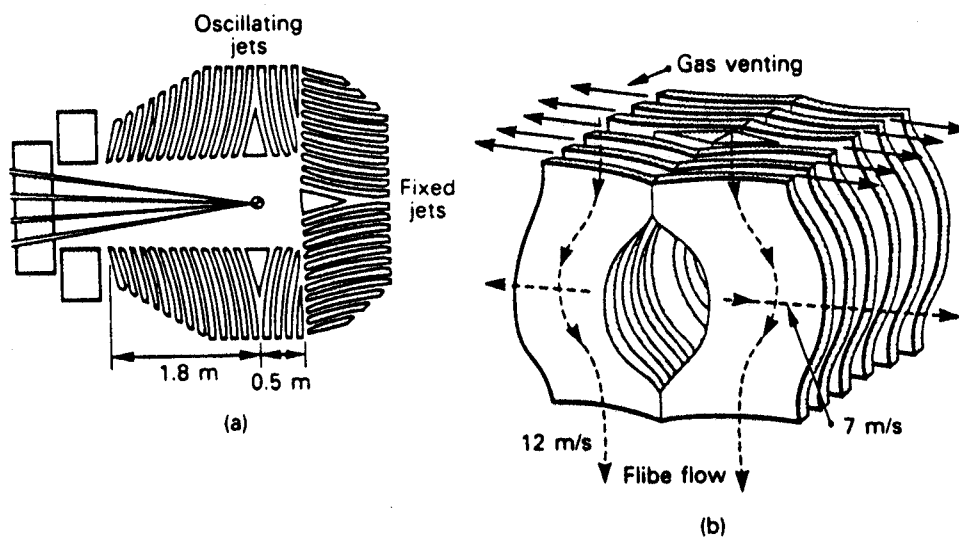

Fig. 3. The oscillating and stationary jets form a pocket that attenuates neutrons but vents vapor rapidly through the space between the liquid sheets or slabs.

# Thin Film Cavity Protection Critical Issues

---

## I. Porous Flow:



- needed injection and seepage rates
- thickness uniformity
- flow around geometric perturbations

## II. Inverted Surfaces:

- inertial jet behavior on endcap 
- capillary adhesion to inverted surface

## III. Drainage from zero pressure cavity

## IV. Film flow stability and response to impulsive loading:

- soft X-ray ablation impulse 
- isochoric heating relaxation 
- cavity gas shock relaxation 

## V. Compatibility and wetting of liquid/solid combinations

## VI. Cavity clearing and vapor condensation

---

# Modeling of Inverted Hemisphere Flow fed from an Inertial Jet

---

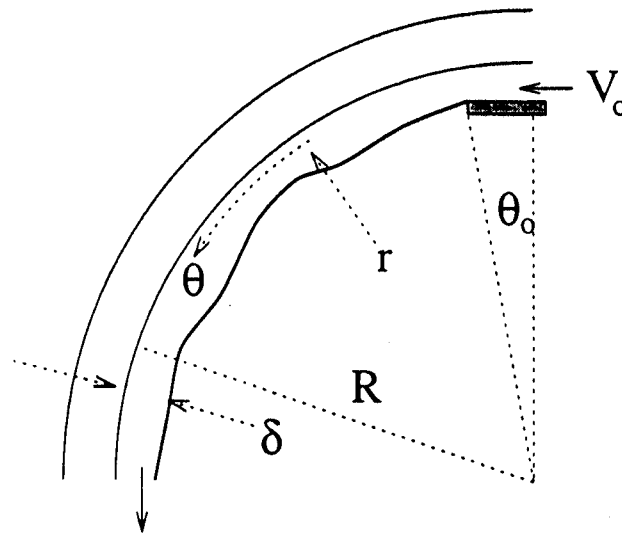

Simplified 1-D fluid equations in spherical geometry:

$$\begin{aligned} \frac{\rho V_\theta}{R} &= \frac{\partial p}{\partial r} + \rho g \cos \theta \\ \frac{\rho V_\theta}{R} \frac{\partial V_\theta}{\partial \theta} &= -\frac{1}{R} \frac{\partial p}{\partial \theta} + \rho g (\sin \theta - \tau_M) \\ \frac{\partial}{\partial \theta} (V_\theta \delta \sin \theta) &= R \sin \theta \frac{\kappa}{\nu \rho} \frac{(p_c - p(0))}{t_{wall}} \end{aligned}$$

- $V_\theta$  = velocity in  $\theta$  direction,  $\delta$  = film thickness
- $g$  = acceleration of gravity,  $\kappa$  = material permeability
- $\tau_M = V_\theta^2 n^2 / \delta^{4/3}$  = manning's turbulent head loss formula
- model assumes  $V_r \ll V_\theta$  to eliminate small inertial terms
- similar to PROMETHEUS analysis but including the pressure coupling as third variable

# Some Results from Endcap Analysis

## Flow Profiles:

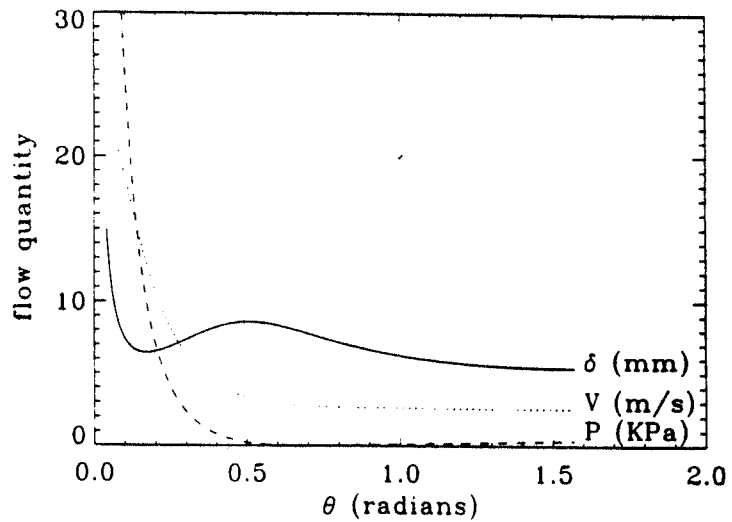

- final height/velocity affected only by initial flowrate  
 $Q_o = \delta_o V_{\theta_o} \cdot 2\pi R \sin \theta_o$ . Not by them individually.

## Inertial adhesion:

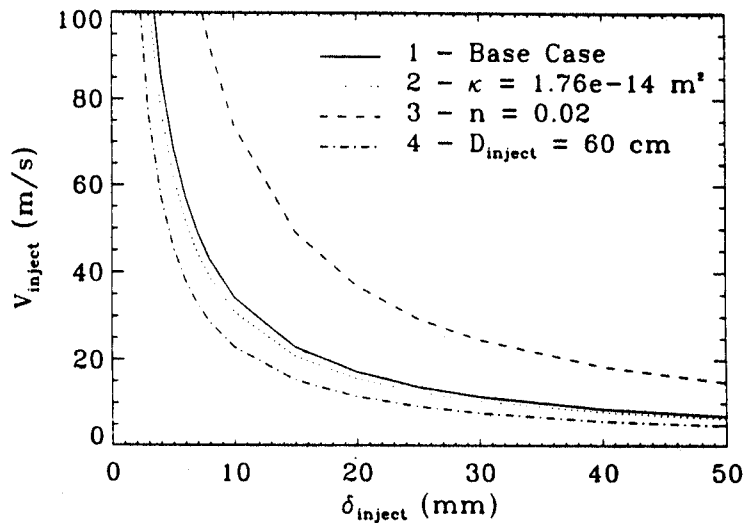

- base case ( $n=0.012$ ,  $\kappa=0.0$ ,  $D_{\text{inject}} = 40 \text{ cm}$ ) traces contour of constant  $Q \approx 0.42 \text{ m}^3/\text{s}$
- increase in drag ( $n$ ) increases required  $Q$  linearly in this range
- increase in seepage ( $\kappa$ ) slightly reduces required  $Q_o$ , but  $Q_{\text{total}}$  is larger than without seepage

# Pressure Loading on Thin Film Flows

---

## I. Cavity gas shock relaxation:

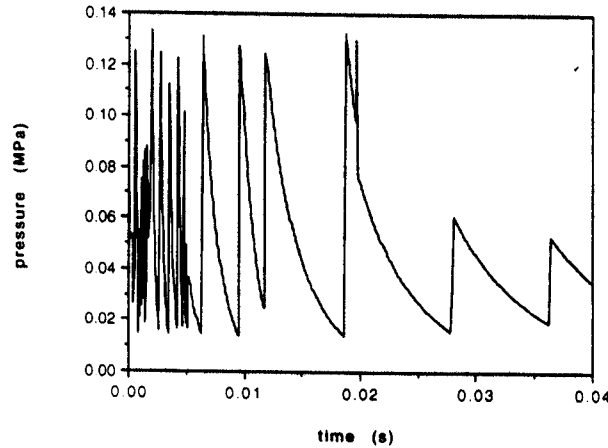

- long time scale (rise time  $\sim 50 \mu\text{s}$   $>$  pressure wave transit time  $\sim 1 \mu\text{s}$ ), liquid film is incompressible

## II. X-ray ablation impulse:

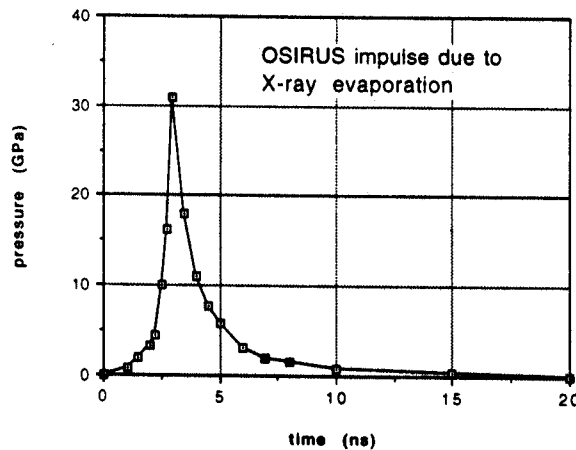

- short time scale (6-50 ns) ablation produces high pressures at liquid surface
- time scale short compared to sound wave transit time, shock is launched into liquid film

# Incompressible Free Surface Computer Modeling

---

## RIPPLE<sup>1</sup>

- incompressible. Eulerian. transient fluid code
- two-dimensional Cartesian or cylindrical geometries
- variable size rectilinear mesh
- built-in or user defined boundary conditions

## Modifications:

- CSF model altered to include transient, spatially variable surface momentum flux
- unsteady outflow boundary condition added
- seepage through substrate based on Darcy equation

## Limitations:

- cell aspect ratio should lie between .5 and 2 - limits solution space size (about 5cm in length)
- initial height and velocity determined with  $Re$  to limit change in height (required solution space)
- laminar flow

---

<sup>1</sup>D.B. Kothe, R.C. Mjolsness, M.D. Torrey. *RIPPLE: A computer program for incompressible flows with free surfaces*. Los Alamos National Laboratory, LA-12007-MS, April 1991.

# Initial Conclusions from RIPPLE modeling

---

Pb film at  $Re=200$  and no seepage ...

- film flow is already quite wavy by  $t = 0.2$  s, a typical dwell time between shots
- the blast after 0.00226 s has already disturbed the film, this is about 8 peaks in the the cavity gas pressure
- some wave breaking (droplet formation) is seen in higher resolution plot

Initially stagnant Pb with seepage

- waves do not grow appreciably in intershot dwell time due to lower initial velocity

Initially stagnant Flibe with seepage

- waves do not travel from initial disturbance in typical intershot dwell time

More testing is being done in all cases, under loaded and unloaded conditions

# RESULTS: section of PB flow

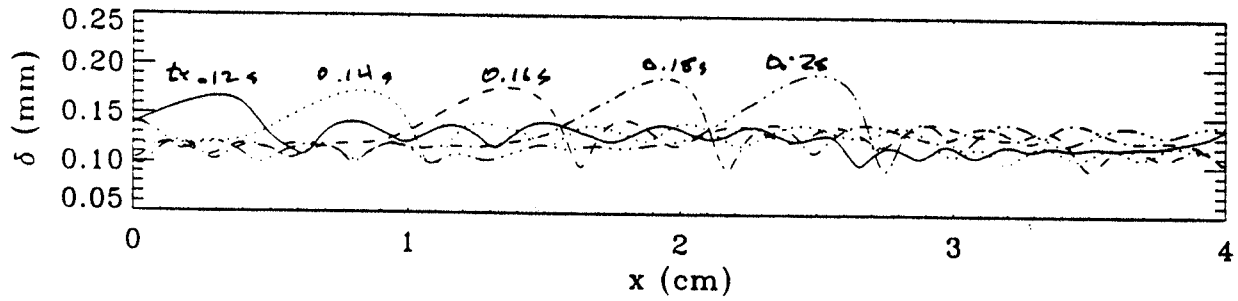

Vertical film flow at  $Re = 200$  with periodic inlet conditions and no inflow through substrate. The solid line is a time  $t = 0.12$  s with subsequent lines every  $0.02$  s

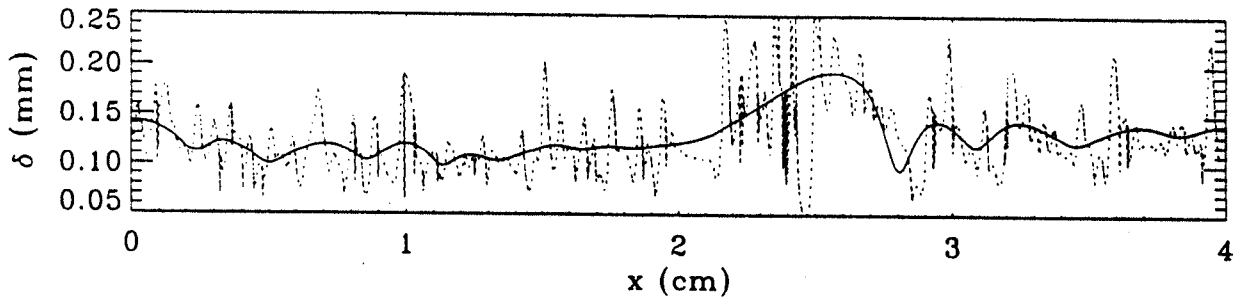

Vertical film flow at  $t = 0.2$  s (solid) and  $t = 0.20226$  s (dotted) with blast commencing at  $t = 0.2$  s

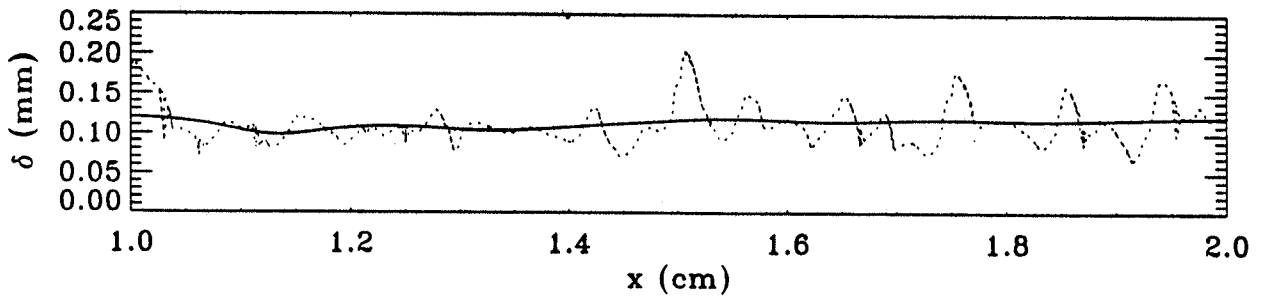

Higher resolution plot of above figure



# Current Research

---

- Thin film compressible analysis
  - a) response of the film/porous plate/backing channel system to:
    - isochoric nuclear heating
    - surface pressure shock
  - b) look for material load and film spallation
  
- Thick jet scientific and engineering assessment and numerical simulation
  - a) jet breakup length with:
    - high Re and We number flows
    - forced jet oscillations
  - b) development of surface ripple
  - c) vapor condensation issues
  
- Experimental program development
  - a) thick jet flows in near vacuum
  - b) thin film flows on porous substrates
  - c) cavity clearing for ablated liquids

67

# Thin Film/Porous Substrate/Backing Channel Modeling

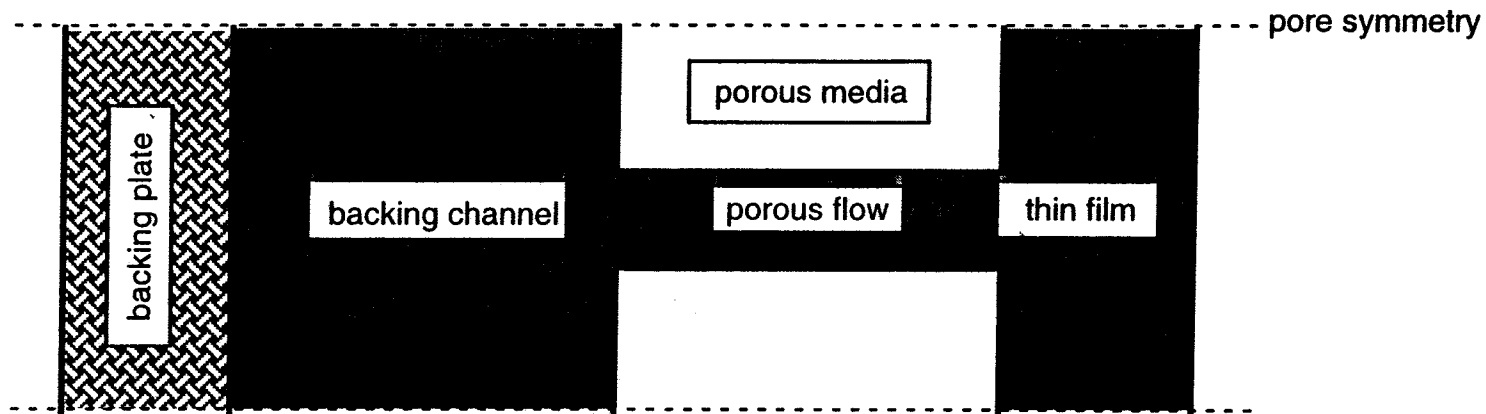

Compressible flow equations in 1D

$$\frac{\partial}{\partial t} \mathbf{f} + \frac{\partial}{\partial x} \mathbf{G}(\mathbf{f}) = 0, \quad \mathbf{f} = \begin{pmatrix} \rho \\ \rho u \\ \rho \cdot (e + u^2/2) \end{pmatrix} \quad \mathbf{G} = \begin{pmatrix} \rho u \\ \rho u^2 + p \\ \rho u \cdot (e + u^2/2) + pu \end{pmatrix}$$

Equations of State (modified gruneisen)

$$p = p_H \cdot (1 - \gamma_0 x/2) + \gamma_0 \rho_0 e, \quad x = 1 - \frac{\rho_0}{\rho}, \quad p_H = \frac{\rho_0 C_0^2 x}{(1 - S \cdot x)^2}$$

# Status of Compressible Modeling

---

- Implementation of the equations of state
- Trial runs on shocktube benchmark problem
- Implementation of moving grid
- Paper to be presented at ISFNT-4

# Thick Jet Numerical Simulations

---

## Deformation of slabs by surface tension

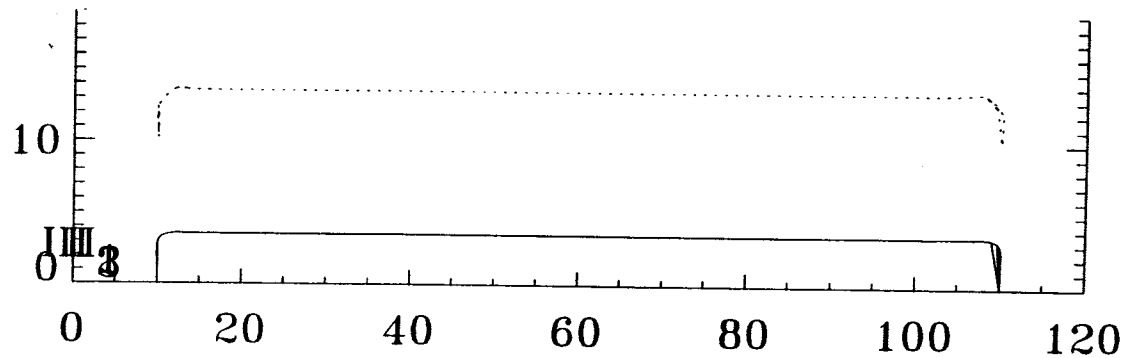

## Jet breakup and surface ripple calculations

- comparison of RIPPLE laminar calculations with theory
- RIPPLE must adapted to turbulent flow
- comparison of RIPPLE results to experiments on cylindrical jet geometry
- RIPPLE calculations of slab geometry, including oscillations of jet

# Existing Experimental Capabilities at UCLA

---

## MEGA loop – LM flow facility

### *Flow Loop*

Maximum Field (T)	0.18
Maximum / Minimum Flowrate (l/s)	0.5, 0.04
LM volume (l)	15
Operating Temperature (C)	60

### *LM Properties*

Composition (%)	44.7 Bi, 22.6 Pb, 19.1 In, 8.3 Sn, 5.3 Cd
Density (kg/m <sup>3</sup> )	9160
Melting Point (C)	47
Viscosity (m <sup>2</sup> /s)	1.8 x 10 <sup>-7</sup>
Specific Heat (J/kg·K)	146.6
Thermal Conductivity (W/m·K)	20

## Miscellaneous equipment and space

- large vacuum vessels appropriate for these tests
- high bay lab space and utilities supplies

## Departmental equipment and expertise

- several major labs on fluid mechanics, heat and mass transfer, manufacturing and composites
- pulsed power laser facilities and laser flow diagnostics expertise

# UCLA Thick Jet Experiments

## Experimental Objectives:

- realization of high  $Re$ ,  $We$  number rectangular jet LM flow
- investigate jet breakup length and surface ripple in working region
- investigate stationary and forced oscillation jets

## LM advantages:

- entrance into vacuum possible without flashing of liquid
- thin elongated jets possible at low flowrates

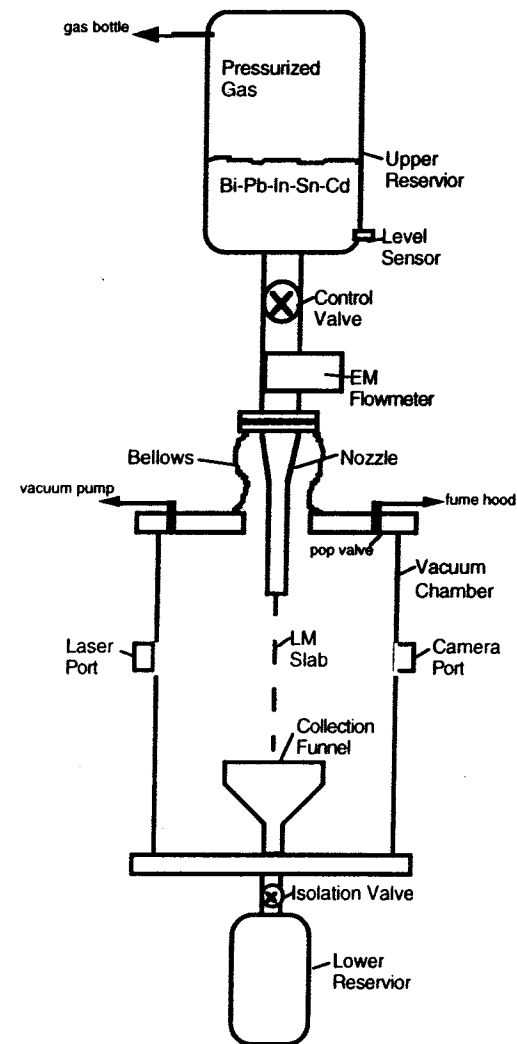

54

# Pre-analysis indicates LM provides better simulation

## Experimental Similarity Parameters

	HYLIFE	Water	LM 1	LM 2
Velocity [m/s]	12.0	20.4	16.0	30.0
Thickness [cm]	7.0	1.9	0.44	0.44
Width [cm]	100	9.0	2.2	2.2
Flowrate [l/s]	840	34.9	1.55	2.9
Fall Distance [m]	2	0.5	0.125	0.125
Fall Time [ms]	167	24.5	7.8	4.2
Reynolds Number [ $10^5$ ]	2.43	2.43	4.0	7.25
Weber Number [ $10^5$ ]	1.03	1.03	0.3	1.03
Dimensionless fall length	28.5	28.5	28.5	28.5
Aspect Ratio	14.3	5	5	5

## Hydraulic analysis:

- Gas pressure of ~66 psi for LM 1 and ~300 psi for LM 2
- Jet accelerates to full speed in < 1 s

Surface tension warping is acceptable within the falling distance

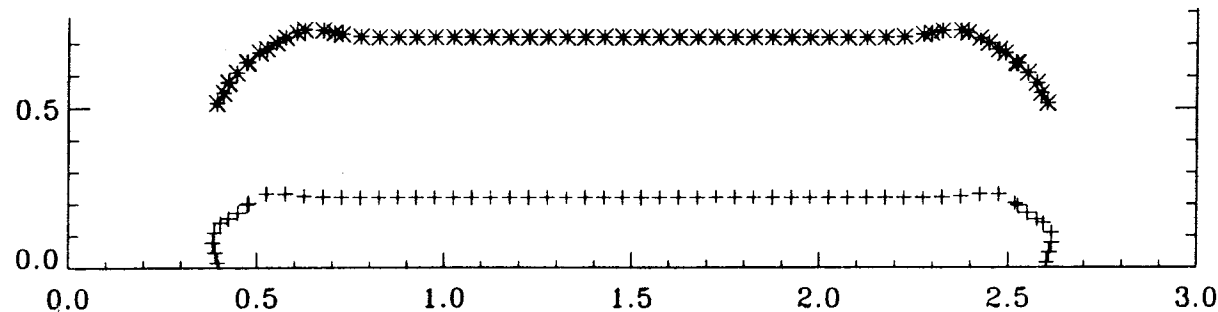

# Thin Film Experiments

## Experimental Objectives:

- measure film flow uniformity on porous media
- measure flow response to vibration, tilting
- response to penetrations
- response to shock loading

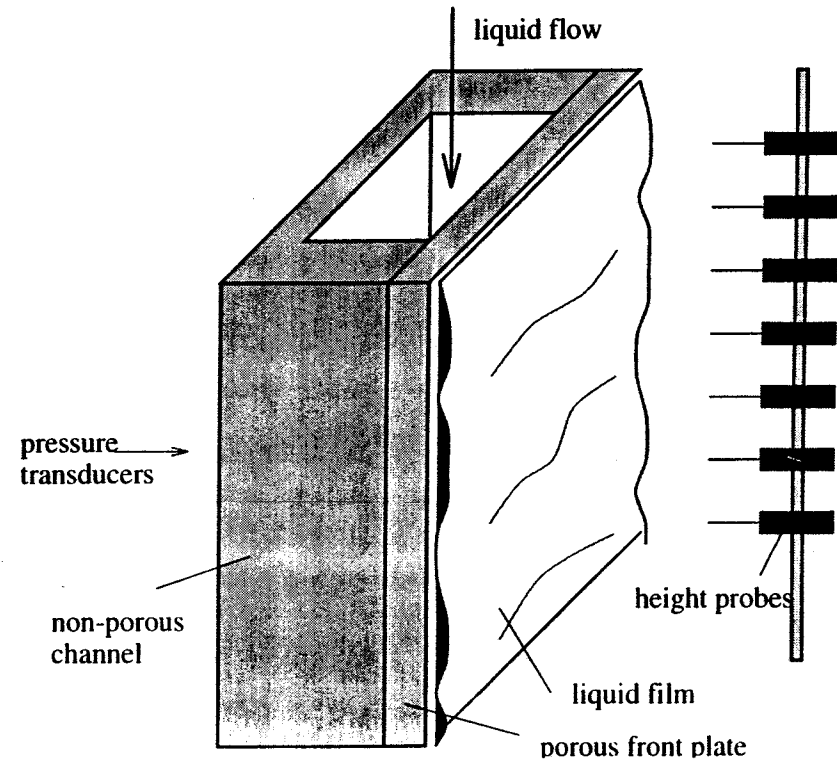



# Summary

---

- UCLA has an established interest and expertise in chamber technology research for the advancement of IFE
- Current research addresses the key issues associated with liquid wall protection schemes
  - a) Fluid mechanics and control issues of thick jet and thin film schemes
    - 1D compressible analysis of film response
    - Experimental and numerical simulation of thick jet flows, jet breakup, surface ripple
    - Experimental and numerical simulation of thin film flows, coverage, obstacles, vibrations
  - b) Study of chamber condensation physics and other cavity clearing issues
- UCLA has in-place experimental facilities for addressing these fluid mechanics problems

# **Neutronic & Activation Issues for NIF/IFE**

**Anil Kumar**

**University of California, Los Angeles**

*Prepared for Presentation for Mark Wilson, DOE/OFE  
at UCLA, Los Angeles, CA  
October 30-31, 1996*

# Neutronic & Activation Issues for NIF/IFE

• *It is important to carry out comprehensive nuclear analysis of NIF facility, using multi-dimensional neutron and photon transport codes, radioactivity codes, and most updated nuclear data libraries. It will be a unique facility of its kind in the world. There is no prior experience. Even though experience on experimental MFE machines does exist, there are important, well-known differences between the two types. There are key issues related to state-of-the-art of IFE chamber technology.*

• *At UCLA, we have been looking into a number of important activation issues that have hardly received satisfactory attention from other workers in the field. In what follows, we would briefly bring up some of the underlying "unusual" nuclear processes, and our contributions. It needs to be noted, however, that a more vigorous effort in these and related areas is called for.*

# Activation Issues for NIF/IFE

## Activation in Various Materials of Target

- Nuclear transmutation reaction rates in a NIF/IFE target need to be calculated carefully as they are governed by spatial and temporal density profiles of various nuclear species present during fusion capsule burn, and, hence, could be strongly impacted by uncertainties in these profiles. Radioactive ash from an exploding target is swept/transported to nooks and corners of structures, in near and far-flung areas.

Improvements in calculations of target activation will also be directly valuable to groups working on D-T neutron based diagnostic techniques to be developed for NIF.

Material composition of NIF/IFE target is obviously an important factor as it is known that different materials activate differently under a given neutron energy spectrum.

## (Cont'd) **Activation Issues for NIF/IFE**

### **Increase of NIF Target/Chamber Activation** **by "Unusual" Nuclear Processes**

- Apart from neutron induced transmutation reactions, there are other nuclear processes that are capable of either completely overshadowing the contribution from the neutron induced reactions or, at least, adding substantially to the latter.

- The nuclear processes identified by us include:

- (i) **Activation due to Supra thermonuclear neutrons**

*Supra thermonuclear neutrons, carrying as much as 20 MeV or more, are produced in high density D-T plasma core from d-t fusion of multiple generations of deuteron and triton recoils.*

→ Reference : "*Impact of supra thermonuclear neutrons on inertial fusion reactor technology*", presented at 2nd Int'l Workshop on Nuclear Data for Fusion Reactor Technology, Del Mar, December 4-6, 1995, and to appear in *Fusion Engineering & Design*.

## **(Cont'd) Activation Issues for NIF/IFE**

### **Increase of NIF Target/Chamber Activation by "Unusual" Nuclear Processes**

#### **(ii) Activation due to photo nuclear reactions and photo neutrons**

*Capture of high energy neutrons in D-T plasma core as well as surrounding structures leads to production of high energy photons, carrying as much as ~30 MeV. These high energy photons are capable of producing additional activation, at least partly due to opening up of additional reaction channels.*

→ Reference : *"Impact of omission of photo nuclear reactions on calculations of D-T neutron shielding experiments for ITER"*, presented at Task T-218 Review Meeting in Garching, Germany in March 1996.

#### **(iii) Activation due to charged particle induced sequential reactions**

*High energy charged particle recoils in D-T plasma core, as well as its close neighborhood, are capable of producing radioactivity that, at times, could overwhelm the neutron induced radioactivity.*

→ Reference : *"Radioactivity Induced by Sequential Reactions in Fusion Materials"*, pp.1010-1013, *Proc. IEEE/NPSS 16th Symposium Fusion Engineering*, G.H. Miley and C.M. Elliott, eds., IEEE, Piscataway, NJ (1996).

# NIF/IFE Target/Chamber Activation Issues

1. For a fusion neutron yield of 20 MJ per shot of Laser driven NIF target, the neutron fluence inside the target during thermonuclear burn could range from  $\sim 10^{18}$  n/cm<sup>2</sup> (*in hohlraum wall*) to  $\sim 10^{23}$  n/cm<sup>2</sup> (*in D-T core*). In comparison, the NIF first wall is subject to a total fluence of  $\sim 10^{13}$  n/cm<sup>2</sup>. A typical NIF gold hohlraum target weighs  $\sim 120$  mg. A 1 cm thick segment of the surrounding NIF chamber weighs  $\sim 8$  ton.

2. We have chosen two LLNL designs. First one is laser driven type for NIF, say, NIF-laser target. The hohlraum wall is made of gold. The capsule is made up of 3 zones as shown in the figure. The second target design is also by LLNL. It was basically designed for heavy ion beam indirect drive with lead as hohlraum wall, say NIF-HIB target. It is much more complex. The total fusion yield is 20 MJ for each target. The core  $\rho R$  of unburnt, compressed D-T core was taken as 3 g/cm<sup>2</sup> and 50% D-T burn was assumed.

3. Neutron transport calculations were done with MCNP and induced radioactivity was calculated with REAC-3. The emphasis is placed on getting dose rate 1 meter away in air from a system component of interest. This brings out the potential of *decay  $\gamma$ -ray radioactivity* component to the full. As for biological dose calculations, we have done  $\gamma$ -ray transport calculations through the NIF first wall and surrounding shield. However, we will focus *only on the dose rate in air to bring out the enhancement in activation due to supra thermonuclear neutrons (in the latter part of this presentation)*.

4. Additional REAC-3 calculations were done by replacing only hohlraum wall (Pb) of NIF-HIB target with other materials, keeping same thickness. Alternative hohlraum materials included Au, W, Ta, Hg, Bi, Pt, and SiC, among others.

# Two LLNL Targets

NIF - Laser Driven Target  
(20 MJ)

Au weight = 127 mg

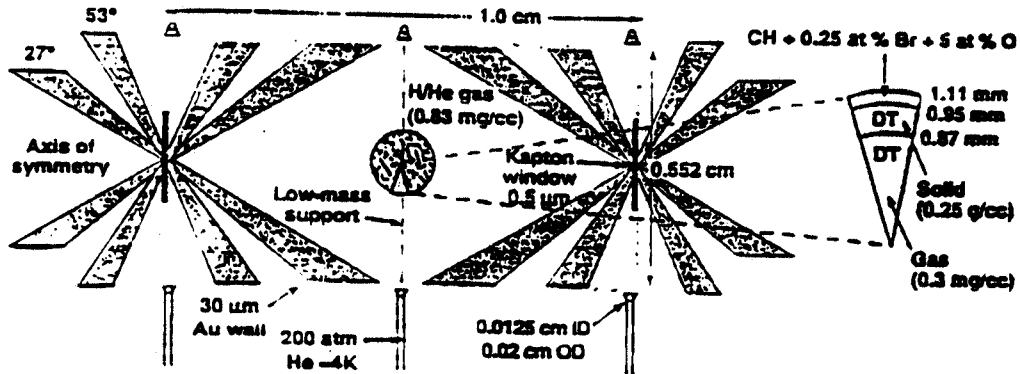

Figure 2. A possible NIF target design that may achieve as much as 20-MJ yield. Target will be inserted from the horizontal on cryogenic capillary tubes.

70-37-0000-100 (1/80)

HIB Driven type Target  
(20 MJ)

Pb hohlraum wall weight = 306 mg

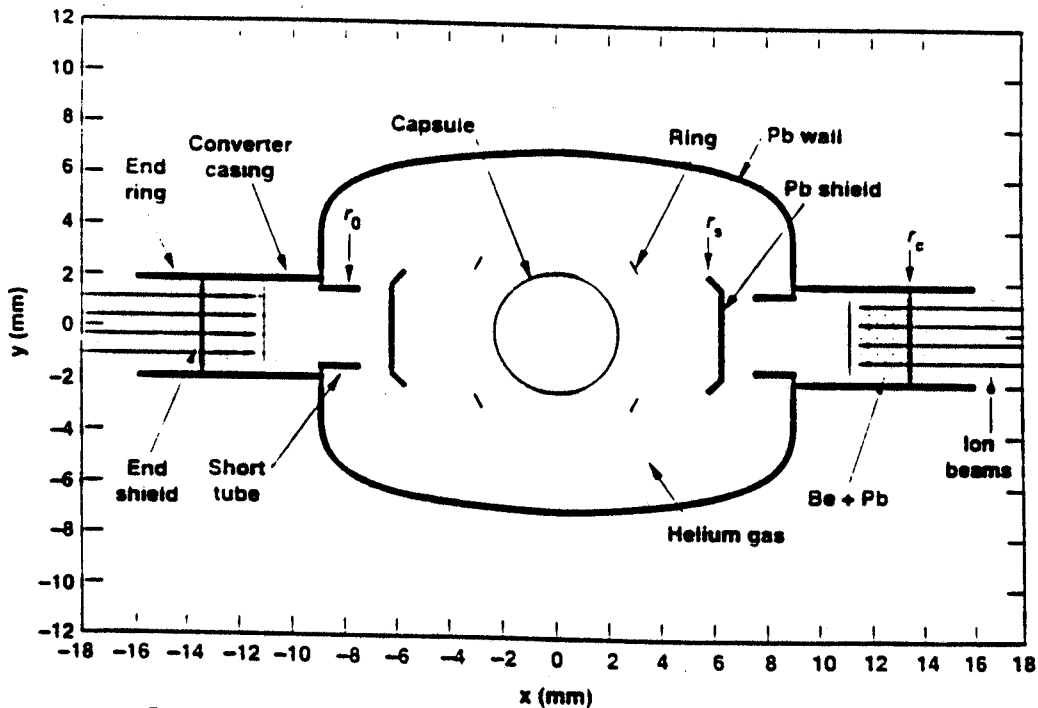
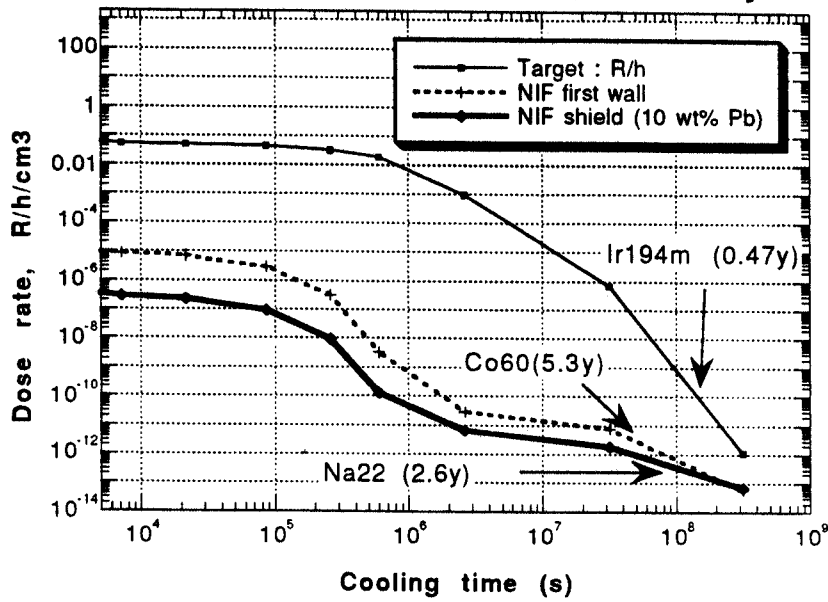

Figure 9. Hohlraum configuration with two-sided illumination geometry.

18200000



**Comparison of Target, NIF First wall,  
and NIF Dose rates  
(Laser driven target of LLNL, 20 MJ yield)**



**Comparison of Target, NIF First wall,  
and NIF Dose rates  
(HIB driven type target of LLNL, 20 MJ yield)**

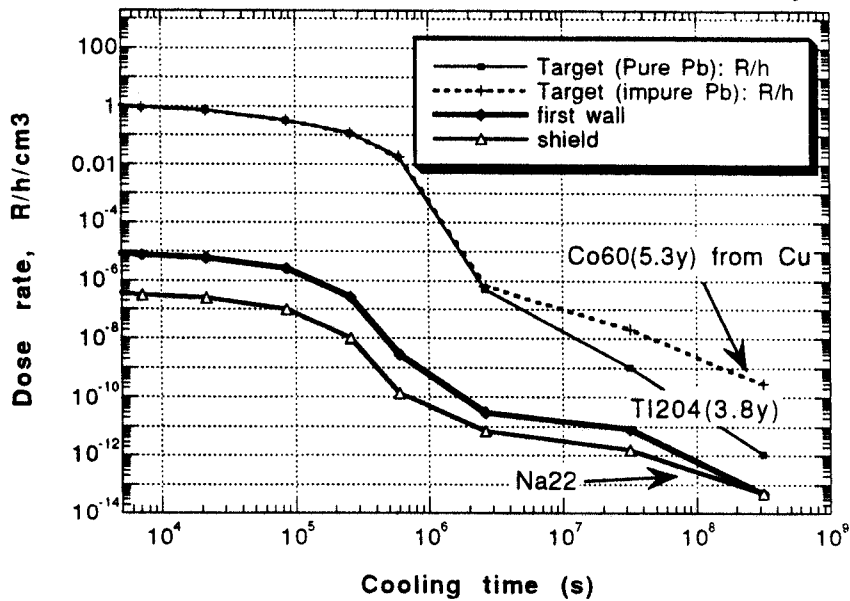

65

Relative Target Dose rates for various Hohiraum Wall materials (HIB driven type target of LLNL, 20 MJ yield)

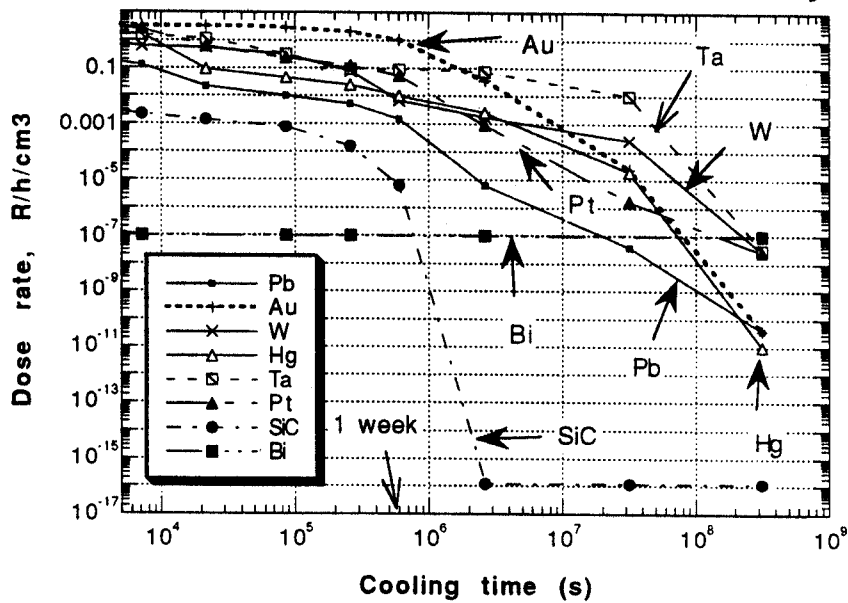

## Table 1

**Fractional contributions to dose rates after a 10 year cooling time following a 20 MJ shot of a LLNL Heavy Ion Beam type Target at NIF**

Material	Leading isotopic contributors
Al-5083 First Wall	$^{60}\text{Co}$ (5.3y,92.4%), $^{54}\text{Mn}$ (312d,3.1%), $^{26}\text{Al}$ (0.72My,3.5%), $^{65}\text{Zn}$ (244d,0.9%)
Shield with 10 wt% Pb	$^{22}\text{Na}$ (2.6y,98.6%), $^{54}\text{Mn}$ (312d,1.4%), $^{26}\text{Al}$ (0.72My,.024%)
Pb as Hohlraum wall	$^{204}\text{Tl}$ (3.8y,98.6%), $^{205}\text{Pb}$ (14My,1.4%)
Ta as Hohlraum wall	$^{179}\text{Ta}$ (1.8y,99.9%), $^{182}\text{Ta}$ (0.3y,8.5e-2%), $^{178\text{m}2}\text{Hf}$ (31y,3.4e-3%)
SiC as Hohlraum wall	$^{26}\text{Al}$ (0.72My,100%)
Hg as Hohlraum wall	$^{195}\text{Au}$ (0.5y,99.2%), $^{194}\text{Au}$ (1.6d,0.46%), $^{193}\text{Pt}$ (50y,0.36%)
W as Hohlraum wall	$^{179}\text{Ta}$ (1.8y,99.87%), $^{178\text{m}2}\text{Hf}$ (31y,0.12%)
Au as Hohlraum wall	$^{194\text{m}}\text{Ir}$ (0.5y,99.97%), $^{192}\text{Ir}$ (0.2y,0.0048%)
Bi as Hohlraum wall	$^{208}\text{Bi}$ (0.37My,99.38%), $^{207}\text{Bi}$ (38y,0.62%), $^{210\text{m}}\text{Bi}$ (3My,0.0013%)
Pt as Hohlraum wall	$^{193}\text{Pt}$ (50y,96.42%), $^{192}\text{Ir}$ (74d,2.6%), $^{194}\text{Ir}$ (19h,0.97%) [ $^{194}\text{Ir}$ comes from $^{194\text{m}}\text{Ir}$ (0.47y)]

## Comments on Results (Thermonuclear neutron source)

1. For NIF, the dose rate at 1 m in air from 20 MJ 'target' is 5 orders of magnitude larger than that from the NIF first wall for both the targets, i.e. NIF-laser and NIF-HIB, after a cooling time of ~1 day. For 10 year cooling time, the 'target' activity is at least an order of magnitude larger than that from the first wall.

2. Impurities play very important role in enhancing radioactivity. For example, for NIF-HIB target, the presence of even minute quantities of impurities in lead (*Pb*: 99.92 at%, *Ti*: 0.0043 at%, *Cu*: .016 at%, *Ag*: .0096 at%, *Sn*: .028 at%, *Bi*: .023 at%) leads to more than 2 orders increase in activity for a 10-year cooling time. The major culprits are  $^{60}\text{Co}$ (5.3 y half life),  $^{108\text{m}}\text{Ag}$ (127 y),  $^{121\text{m}}\text{Sn}$ (55 y).

3. As for alternative hohlraum materials with 100% pure composition, for NIF-HIB target, the following sequence of observed dose rates from the hohlraum component of the 'target' is found (from low to high) for a 10 year cooling time: SiC, Hg, Au, Pb, Pt, W, Ta, and Bi.

4. Activated target debris are much more radioactive than the NIF first wall. As the number of neutron producing shots increases, the cumulative decay rate due to the debris could rise to unacceptable levels. In addition, the activated shrapnel from the target positioner and the target manipulation tubes will make a large contribution to the dose rates inside the NIF chamber. If these debris were allowed to pile up on the inside surface of the NIF chamber, they could be a floating source of radioactivity. Possibly, a part of this activity may eventually reach low activation areas outside the NIF chamber. Thus, it might be needed to remove these radioactive debris from time to time. Also, these activated debris are likely to be qualified as higher level of radioactive waste due to such a large differential with respect to the NIF first wall. As for target positioner and manipulator tubes, the best bet lies in going for low activation structural materials.

Continued  
**Comments on Results**  
(Thermonuclear neutron source)

5. For IFE machines, it is simply impermissible to allow significant amount of the target debris to get deposited on the surface of the first wall. The material properties of the deposited layer will be very different from that of the original first wall- with all consequences one could think of.

6. *For IFE reactor conditions, even if activated debris were to be transported out of the IFE chamber, one would have to provide large amount of  $\gamma$ -ray shielding at "storage" or "reprocessing facility".*

7. Even a 20 MJ single shot at NIF is likely to yield a fluence as high as  $\sim 10^{18}$  n/cm<sup>2</sup> at the hohlraum wall. This opens up an important possibility of measuring/testing activation cross-section data for long-lived radioactive products that will be generated in first wall of DEMO reactors. Such high fluences are very, very difficult to achieve otherwise. In a hohlraum target, for example, one could encapsulate the target inside a thin shell of this "DEMO" material. Our calculations show that it will be possible to produce countable quantity of long-lived activity in practically all materials of interest for fusion.

## Comments on Increase in Radioactivity due to Supra thermonuclear neutron source

- In a compressed D-T core (in IFE plasmas), where  $\rho R$ , say, optical thickness, is expected to be in the range of  $3 \text{ g/cm}^2$  or more, both thermonuclear fusion neutrons ('14 MeV') and alphas ('3.5 MeV') could undergo nuclear elastic and large-angle coulomb scattering collisions with the host d/t ions and impart relatively significant amount of their energy to the latter. These recoiling d/t ions have a possibility of undergoing supra thermonuclear fusion before merging with the Maxwellian, thermal background. This process could repeat itself many times over.
- The contribution of neutrons to supra thermonuclear fusion (through d/t recoils) has potential of even raising largest fusion neutron energy (*thanks to kinematics*) above '14 MeV'. Theoretically, one could have neutrons of as high energy as 78 MeV! It is estimated that for such targets, one could look forward to supra thermonuclear neutron fraction of as high as ~10%.
- Calculations of induced radioactivity with REAC-3 were repeated for NIF-HIB 'target' and surrounding structures with 10% additional neutrons above thermonuclear D-T neutron energy of 14 MeV. The energy distribution of these neutrons was uniform and extended upto 20 MeV to simulate impact of supra thermonuclear neutrons.

### Normalized Supra thermonuclear Neutron Energy Spectrum

density = 700 g/cm<sup>3</sup> ; 50% d + 50% t  
optically thick medium

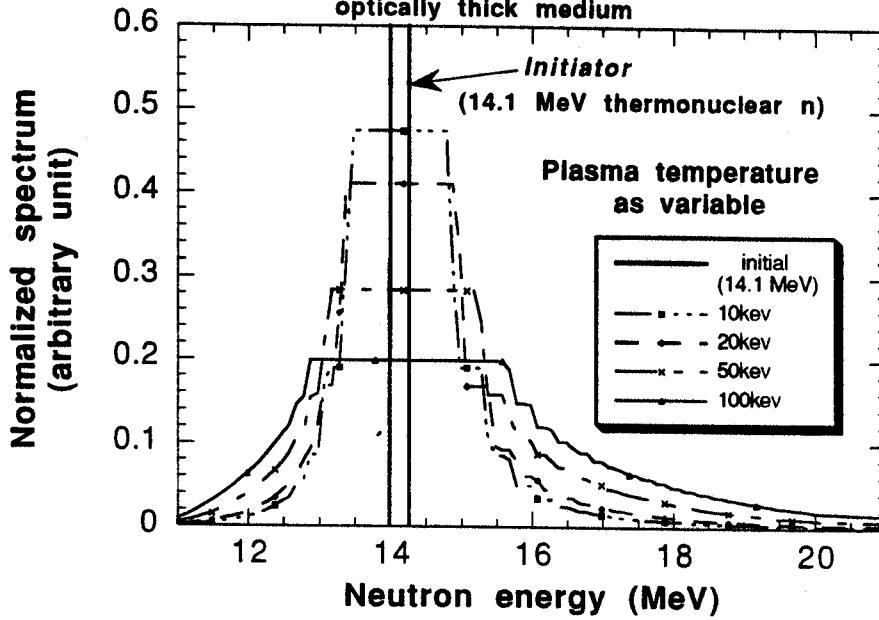

### Si28(n,x)Al26 and Si28(n,x)Al27 Cross-sections

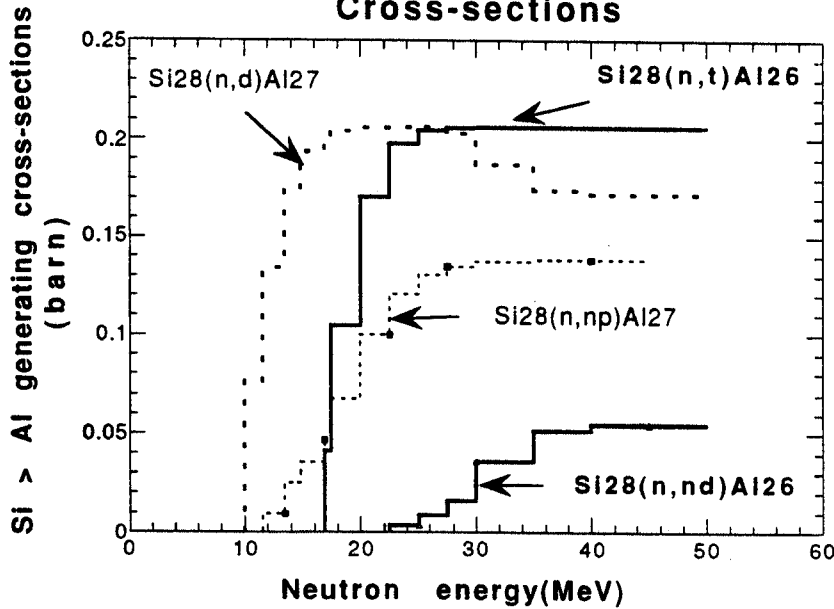

71

### Au197(n,3n)Au195m and Au197(n,3n)Au195 Cross-sections

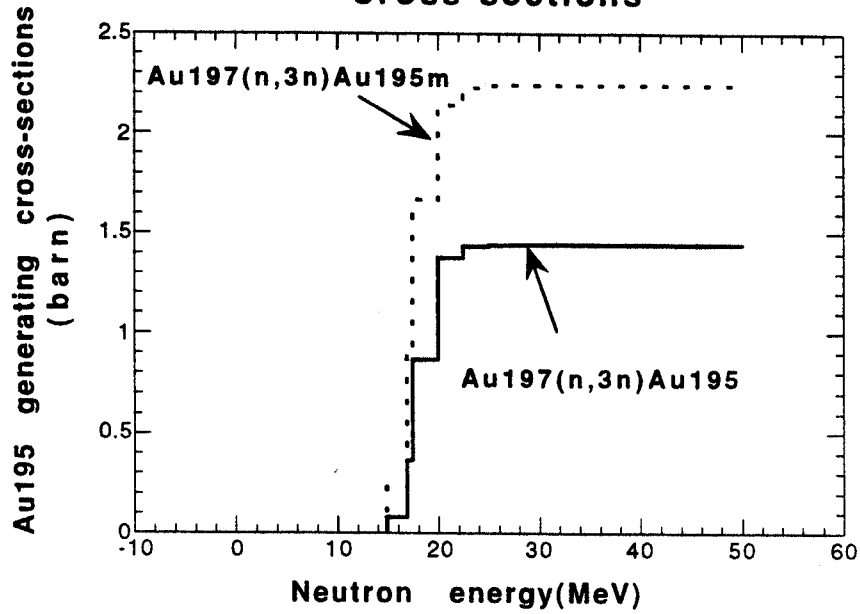

### Hg196(n,3n)Hg194 Cross-section

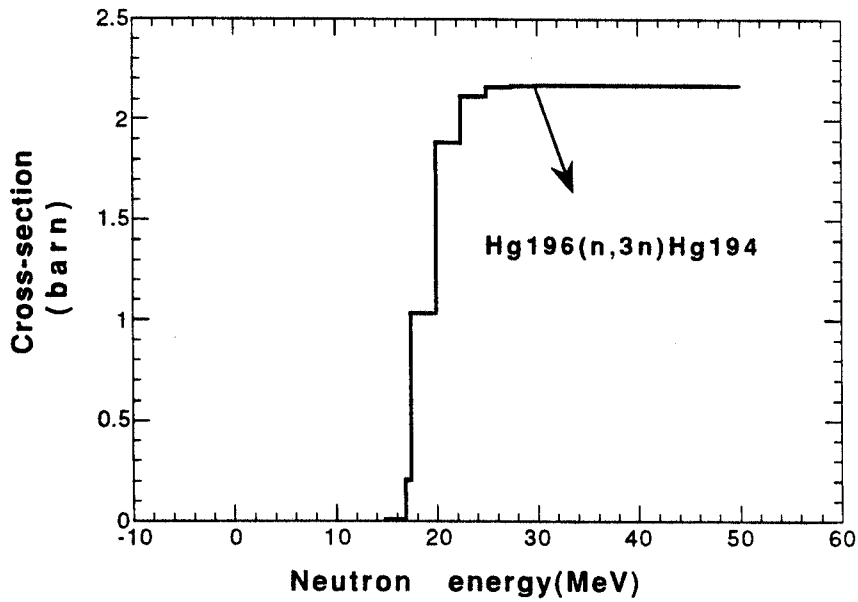



**Impact of Suprathermal Neutrons on  
Target, NIF First Wall and Shield Dose Rates  
after a single 20 MJ shot**  
10% Suprathermal neutrons added (<20MeV)

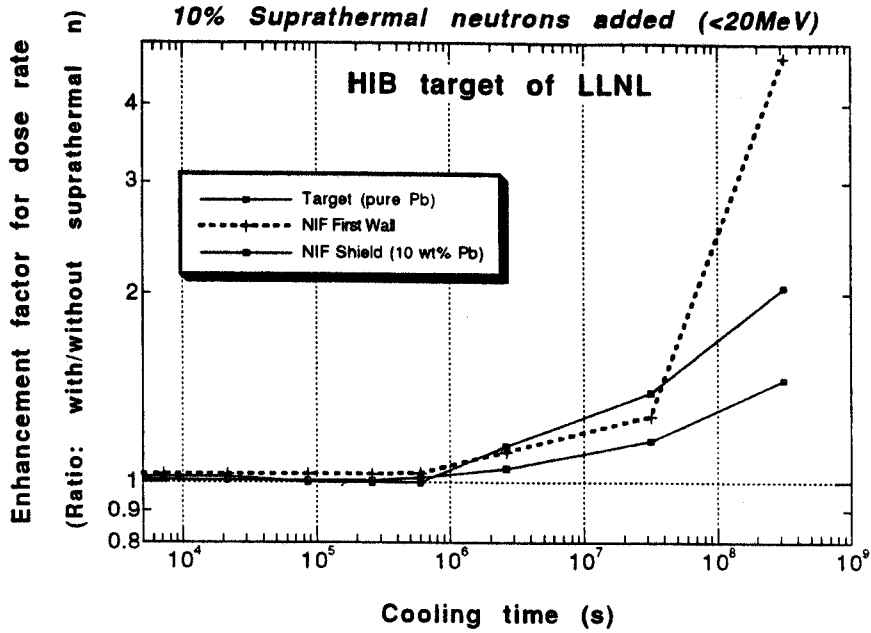

**Impact of Suprathermal Neutrons on Hohlraum Dose rate  
after a single 20 MJ shot**

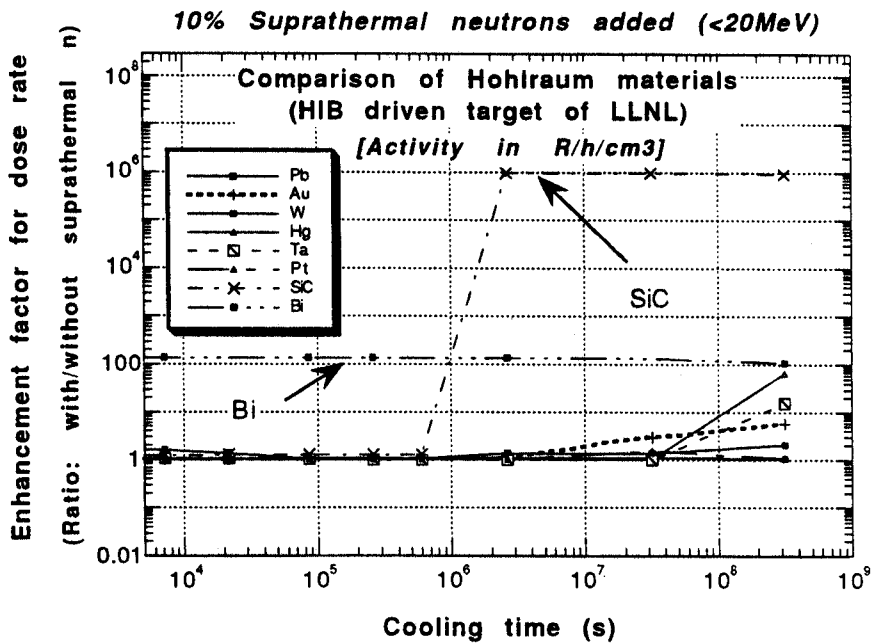

## Table 2

**Radioactive products most impacted by supra  
thermonuclear neutrons<sup>a</sup>**

Material	Ratio of dose rates with and without supra thermonuclear neutrons for 10 year cooling time
<b>Al-5083</b> First Wall	<sup>22</sup> Na (half life = 1.8y) : infinity [ <sup>24</sup> Mg(n,t) <sup>22</sup> Na] <sup>26</sup> Al (half life = 0.72My) : 1.59 [ <sup>27</sup> Al(n,2n) <sup>26</sup> Al]
<b>Shield with</b> 10 wt% Pb	<sup>26</sup> Al (half life = 0.72My) : 2.16 [ <sup>27</sup> Al(n,2n) <sup>26</sup> Al] <sup>22</sup> Na (half life = 1.8y) : 1.46 [ <sup>23</sup> Na(n,2n) <sup>22</sup> Na]
<b>Pb</b> as Hohlraum wall	<sup>202</sup> Tl (half life = 12.2d) : infinity [ <sup>204</sup> Pb (n, 3n) <sup>202</sup> Pb > <sup>202</sup> Tl , <sup>204</sup> Pb (n, 3n) <sup>202m</sup> Pb > <sup>202</sup> Tl, <sup>202m</sup> Pb > <sup>202</sup> Pb > <sup>202</sup> Tl ] <sup>b</sup>
<b>Ta</b> as Hohlraum wall	<sup>179</sup> Ta (half life = 1.7y) : 15.5 [ <sup>181</sup> Ta (n, 3n) <sup>179</sup> Ta ]
<b>SiC</b> as Hohlraum wall	<sup>26</sup> Al (half life = 0.72My) : 0.94 10 <sup>6</sup> [ <sup>28</sup> Si (n, t) <sup>26</sup> Al ]
<b>Hg</b> as Hohlraum wall	<sup>194</sup> Au (half life = 1.65d) : 1.4 10 <sup>4</sup> , <sup>194</sup> Hg (t <sub>1/2</sub> = 520y) : 1.4 10 <sup>4</sup> [ <sup>196</sup> Hg (n, 3n) <sup>194</sup> Hg , <sup>194</sup> Hg > <sup>194</sup> Au ]
<b>W</b> as Hohlraum wall	<sup>178m2</sup> Hf (half life = 31y) : 1.34, <sup>182</sup> Hf (half life = 9 My) : 1.56
<b>Au</b> as Hohlraum wall	<sup>195</sup> Au (half life = 186d) : 2.3 10 <sup>4</sup> , <sup>194m</sup> Ir : 1.4, <sup>193</sup> Pt (half life = 50y) : infinity, <sup>192m</sup> Ir (half life = 241y) : 1.99, <sup>192</sup> Ir (half life = 74d) : 1.99 [ <sup>197</sup> Au (n, 3n) <sup>195</sup> Au ]
<b>Bi</b> as Hohlraum wall	<sup>207</sup> Bi (half life = 32 y) : 1.8 10 <sup>4</sup> [ <sup>209</sup> Bi (n, 3n) <sup>207</sup> Bi ]
<b>Pt</b> as Hohlraum wall	<sup>192</sup> Ir (half life = 74d) : 1.48, <sup>192m</sup> Ir (half life = 241y) : 1.48 [ <sup>192m</sup> Ir > <sup>192</sup> Ir ]

<sup>a</sup> 10 year cooling time following a 20 MJ shot of a LLNL Heavy Ion Beam type Target at NIF. 10% supra thermonuclear neutrons added upto 20 MeV

<sup>b</sup> Responsible reaction

74

## Comments on Increase in Radioactivity (Supra thermonuclear neutron source)

- For the NIF-HIB target, just a 10% supra thermonuclear neutron contribution leads to increase in dose rate of as much as a factor of 2 for the target, 1.5 for the NIF shield, and 4.5 for the NIF first wall. This is due to additional radioactivity generated by proliferation of additional reaction channels due to larger energy of supra thermonuclear neutrons, as explained.
- As for alternative hohlraum materials (100% purity), largest increases are observed for SiC, Bi, Hg, Ta and Au. In fact, SiC dose rate even overtakes that of Pb due to 6 orders raise brought about by opening of  $^{28}\text{Si}(n,t)^{26}\text{Al}$  reaction channel! The new order of dose rates after 10-year cooling time is as follows (*from low to high*) : Pb, SiC, Au, Hg, Pt, W, Ta, Bi. Interestingly, only W and Pt are the least perturbed of all, and, incidentally, have the largest number of naturally occurring stable isotopes!! The responsible reaction channels are listed in Table 2.

# **NEED for EXPERIMENTS at NOVA & NIF**

- *In view of such a large increase brought about by such a small supra thermonuclear neutron source for most of the investigated materials, it is very important to do experimental validation of this increase.*
- *Also, it is to be noted that theoretical models used for calculation of spatial and temporal profiles of supra thermonuclear neutron production and their contribution to induced radioactivity need to be calibrated against the experimental data due to complexity of the underlying nuclear processes.*
- *Measurements at NOVA and NIF are proposed to validate the amounts and types of additional radioactivity produced by the supra thermonuclear neutrons.*
- *The successful experimental validation of these effects will help nuclear scientists to improve their theoretical models, on one hand, and provide needed confidence to the fusion reactor designers, on the other.*

# X-RAY DEPOSITION IN INERTIAL FUSION GRAPHITE AND SILICON- CARBIDE FIRST WALLS

Anter A. El-Azab and M. Z. Youssef

UCLA-FNT TEAM

Refer questions to:

Anter A. El-Azab  
43-133 ENG. IV.  
Mechanical, and Aerospace Engineering Department  
University of California, Los Angeles, CA 90095-1597.

Tel. (310) 825-7421      Fax. (310) 825-2599  
[anter@seas.ucla.edu](mailto:anter@seas.ucla.edu)

Dr. Mark Wilson's visit to UCLA, October 30-31, 1996

# FW PROTECTION

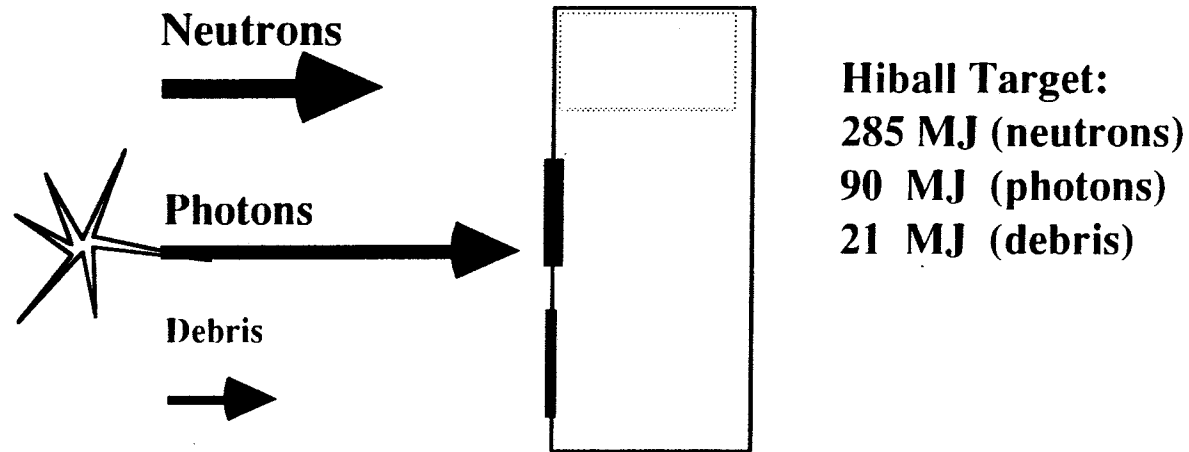

- Damage: melting, vaporization, shocks.
- FW must be protected against photons and debris.
- Gas and film protection Schemes are common choices.
- Gas Protection:
  - Gas density high enough to absorb ALL target x-ray and debris. --> Reradiate over longer periods)
  - Gas density not so high to guarantee beam penetration.

# PHOTON SPECTRA FOR A NUMBER OF ICF(IFE) TARGETS

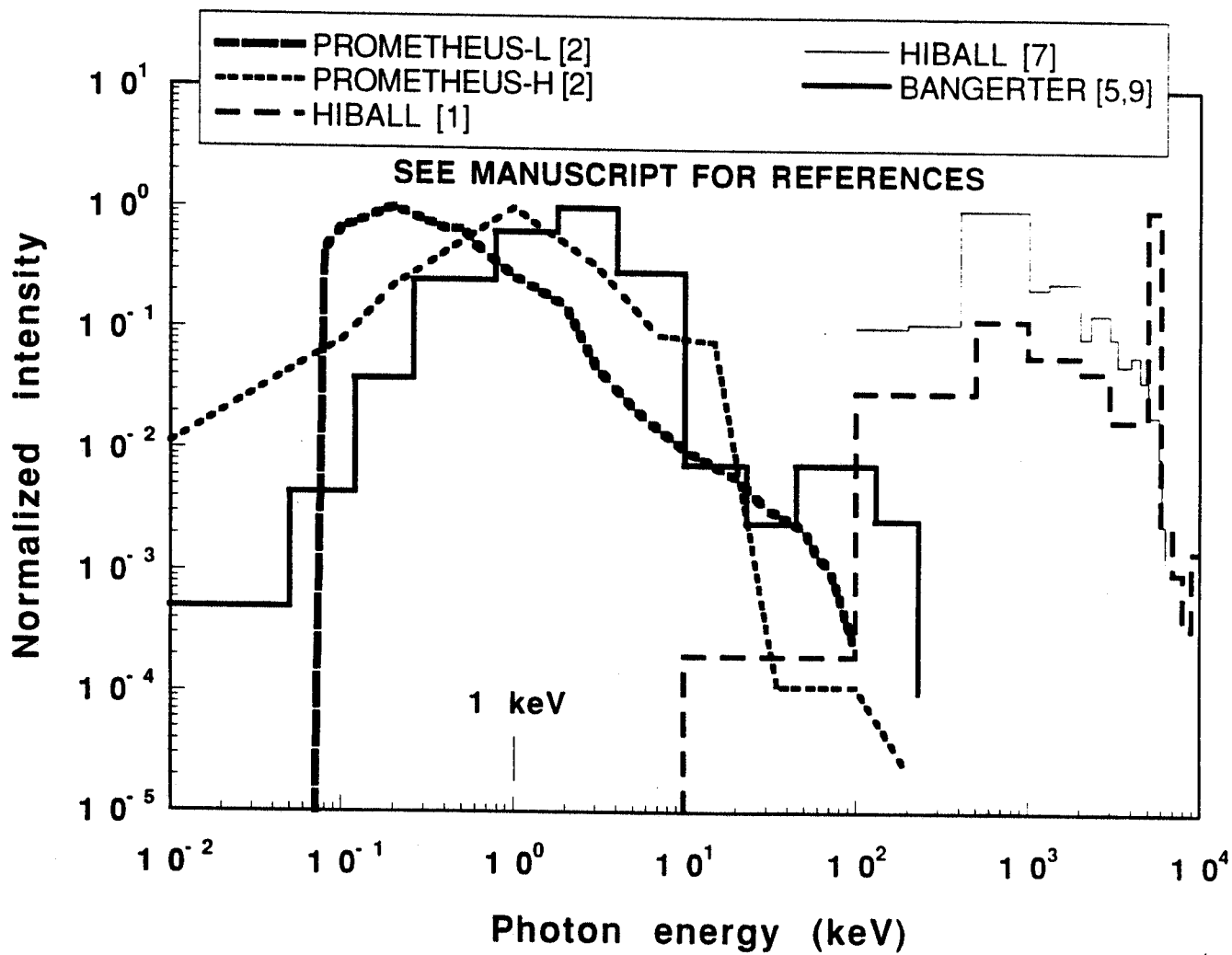

# PRESENT INVESTIGATION

- Energy deposition of typical target x-ray in silicon-carbide and graphite is shown to occur over distances of the order of the first wall thickness for hard x-ray ( $\gamma$ -ray) target spectra, and the resulting maximum instantaneous temperature rise is negligible.
- Photon transport calculations are conducted for cavities of 5m inner radius made of SiC and C, using FENDL library.
- It is shown that, for photons with energies above 1 keV, large fraction of the target photon yield is deposited behind the first wall.
- It is concluded that target x-ray ( $\gamma$ -ray), which represent serious design constraint with metallic first walls, may be of (much) less concern with first walls made of silicon-carbide or graphite.



### Last 14 groups in FENDL Library

Group No.	Upper Energy Boundary (eV)	Lower Energy Boundary (eV)
29	5.10000e+05	4.50000e+05
30	4.50000e+05	4.00000e+05
31	4.00000e+05	3.00000e+05
32	3.00000e+05	2.00000e+05
33	2.00000e+05	1.50000e+05
34	1.50000e+05	1.00000e+05
35	1.00000e+05	7.50000e+04
36	7.50000e+04	7.00000e+04
37	7.00000e+04	6.00000e+04
38	6.00000e+04	4.50000e+04
39	4.50000e+04	3.00000e+04
40	3.00000e+04	2.00000e+04
41	2.00000e+04	1.00000e+04
42	1.00000e+04	1.00000e+03

2

ENERGY DEPOSITION PROFILES IN A 5m  
RADIUS SILICONE-CARBIDE FIRST WALL

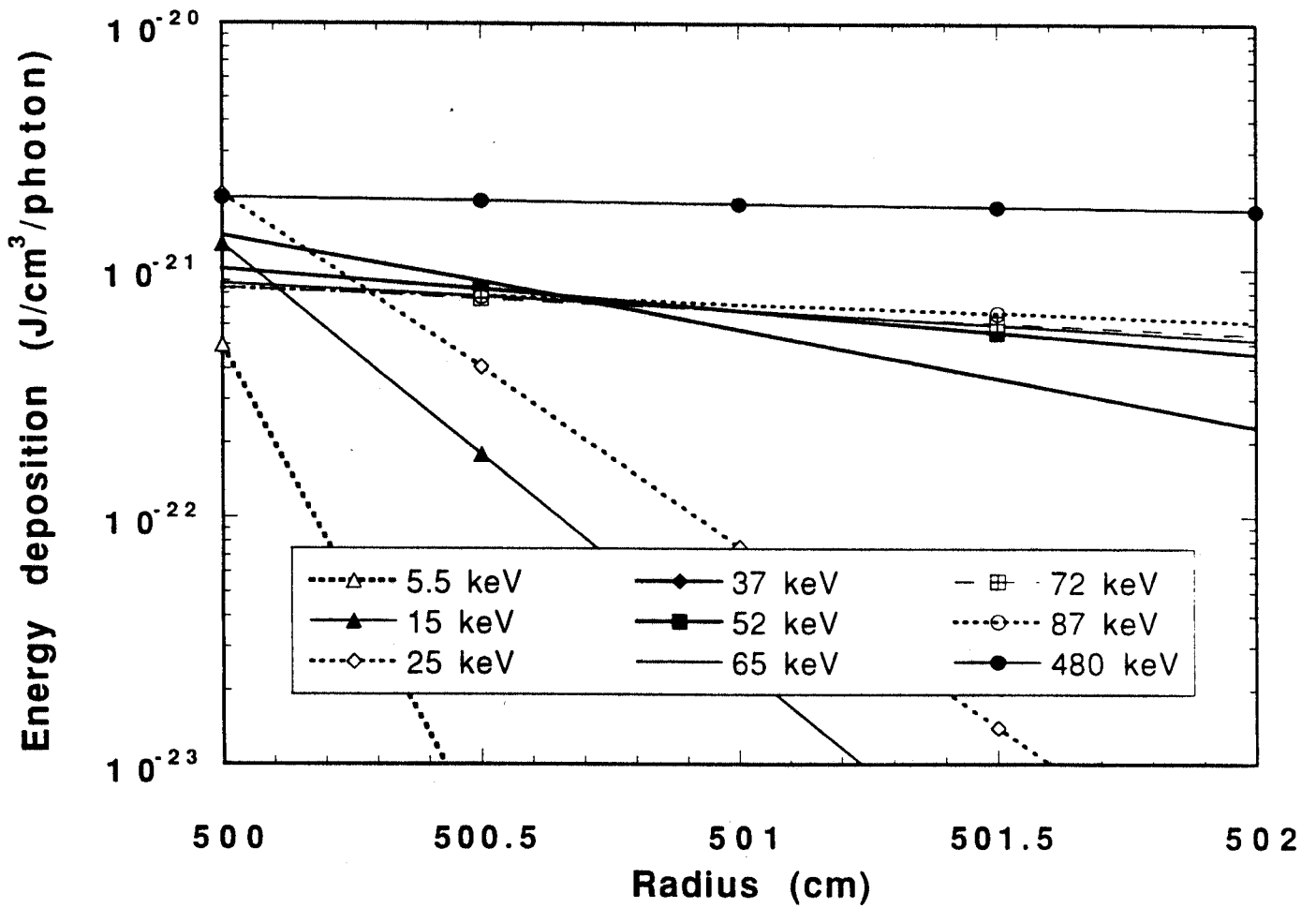

# ENERGY DEPOSITION PROFILES IN A 5m RADIUS GRAPHITE FIRST WALL

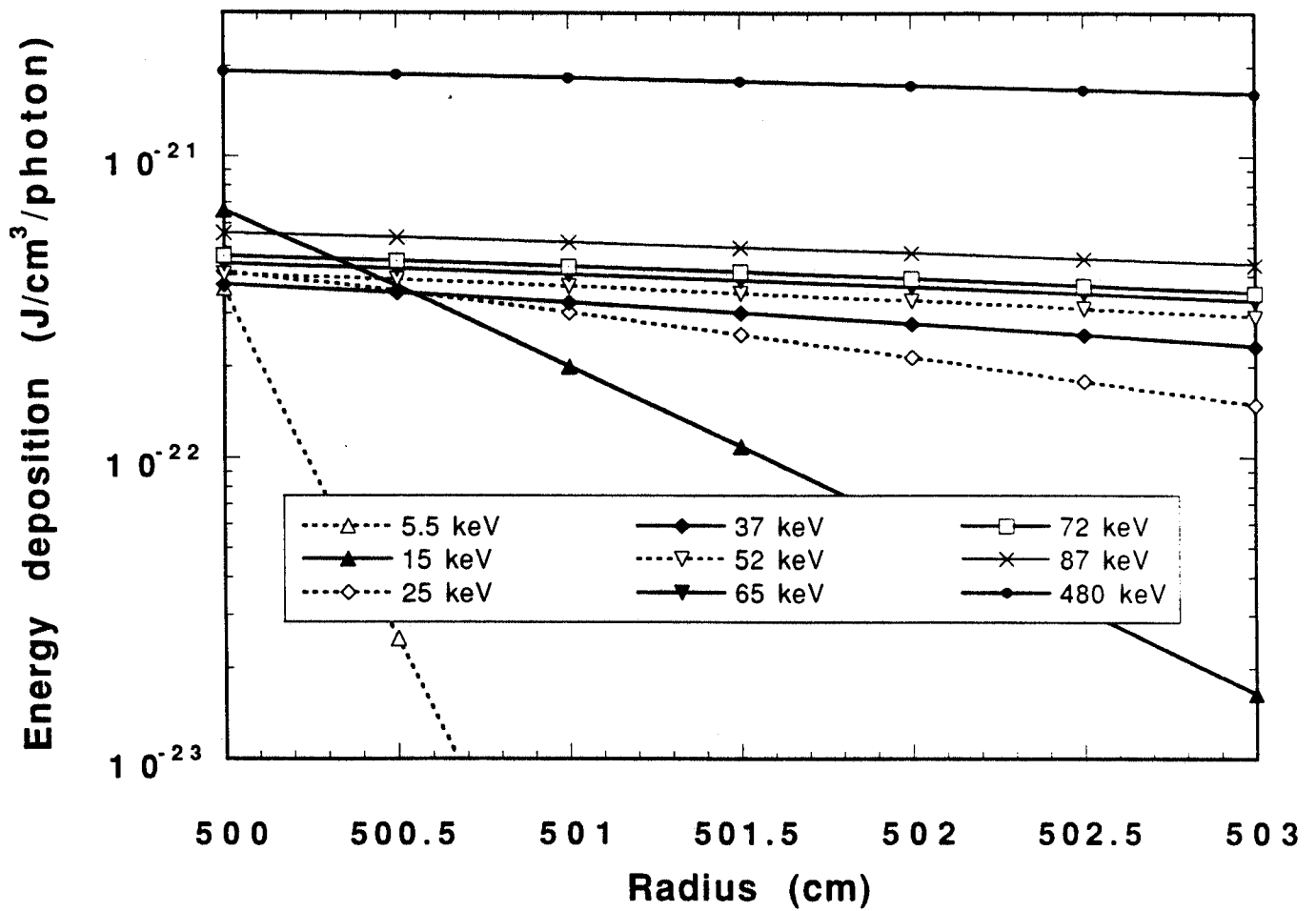

# X-RAYS ENERGY ATTENUATION COEFFICIENTS IN SILICON-CARBIDE AND GRAPHITE

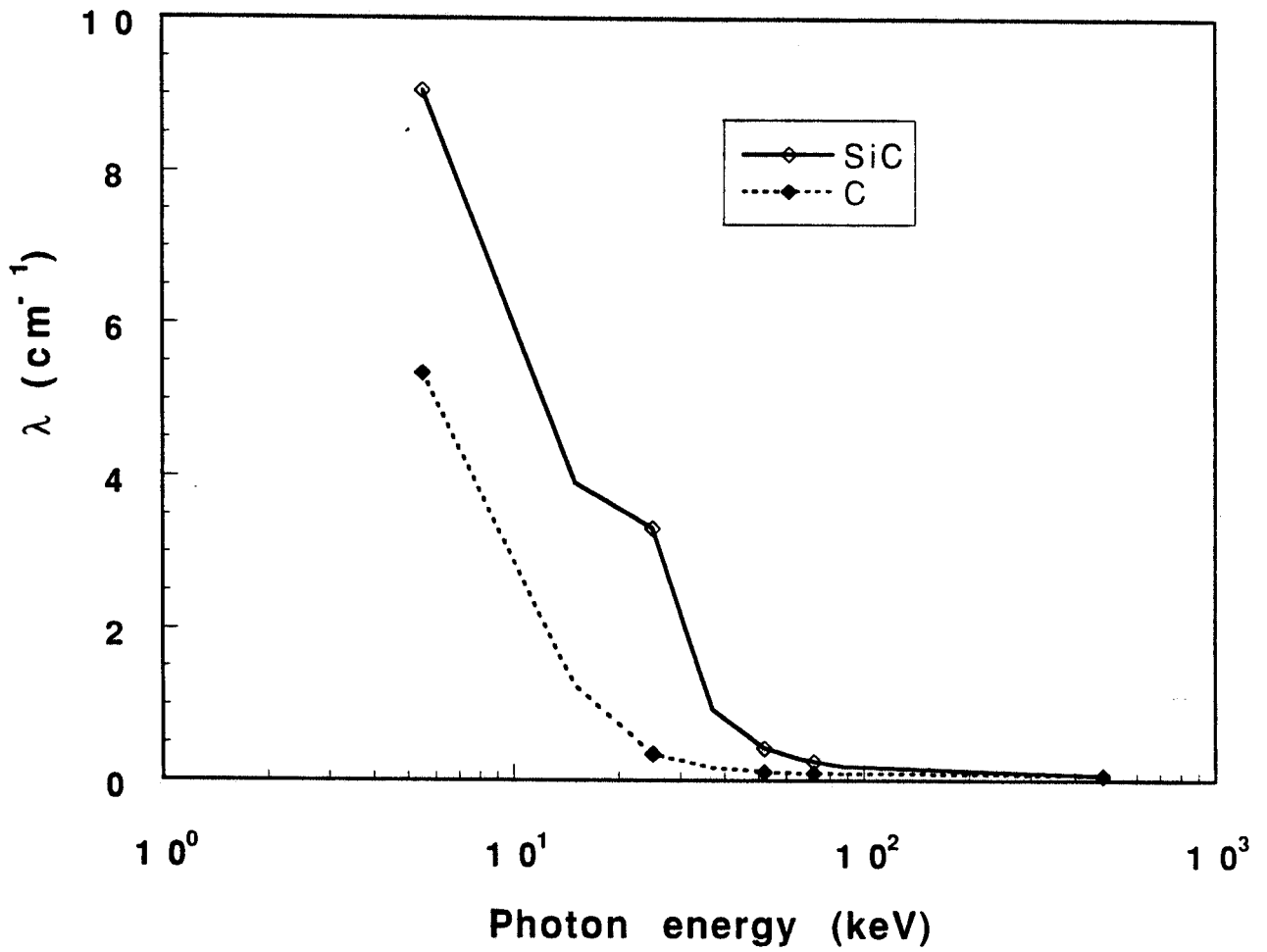

# FRACTIONAL DEPOSITION

The fraction of photon energy which is deposited over a thickness  $x = r - R_c$  (for  $x \ll R_c =$  chamber radius), is given by :

$$Q(x) = \frac{1}{h\nu} 4\pi \int_{R_c}^r r^2 q(r) dr = \frac{4\pi R_c^2 q_c}{\lambda h\nu} [1 - e^{-\lambda x}]$$

where  $q_c =$  deposition density at chamber surface.

# TEMPERATURE RISE

Simple energy balance at chamber surface:

$$\rho c_p \Delta T = \tilde{q}_c$$

Here  $\tilde{q}_c$  is the deposition density at surface due to **100 MJ of x-rays** at a certain photon energy.

# FRACTIONAL DEPOSITION OF PHOTON ENERGY IN A SILICON-CARBIDE FIRST WALL

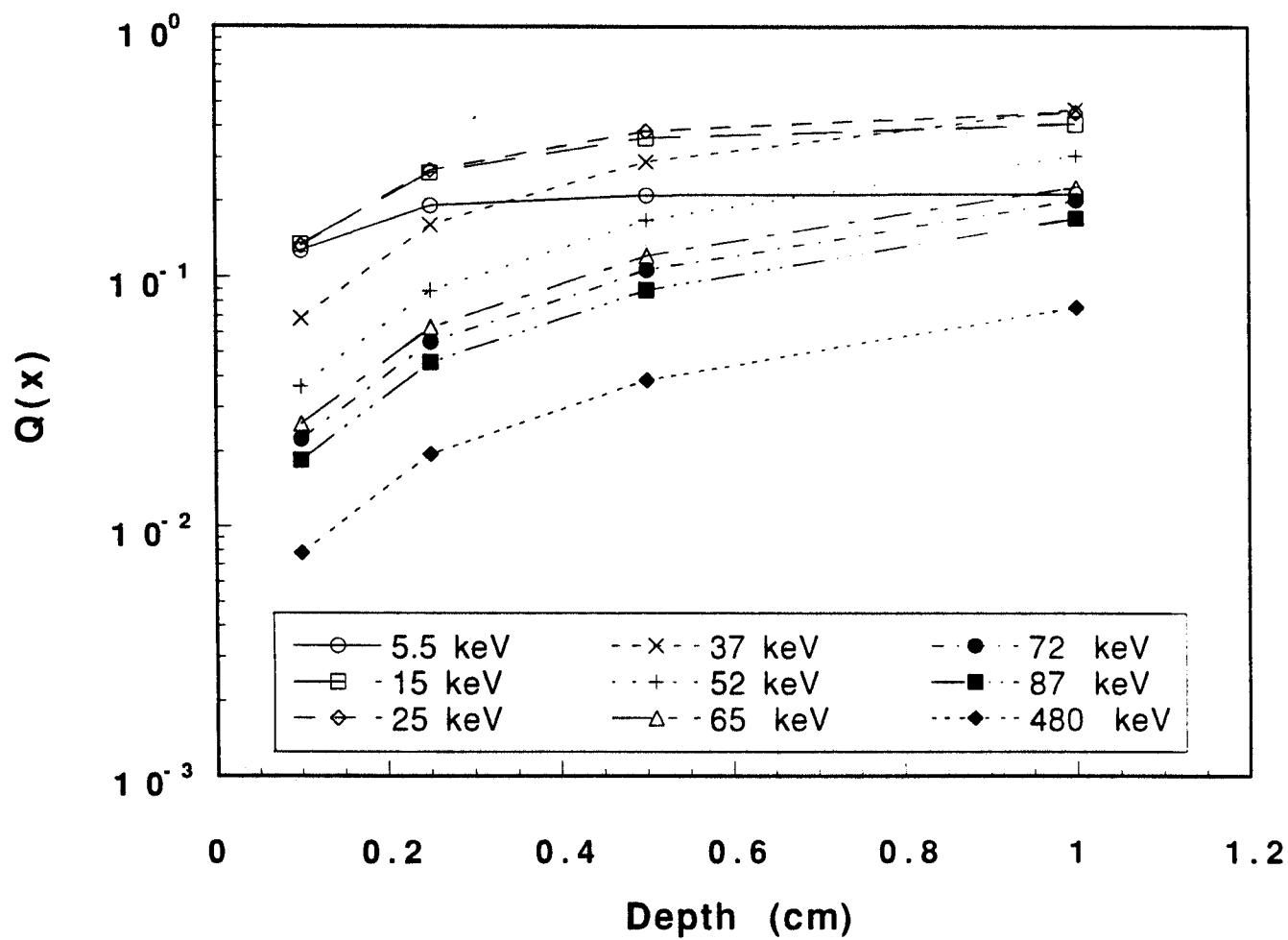

# FRACTIONAL DEPOSITION OF PHOTON ENERGY IN A GRAPHITE FIRST WALL

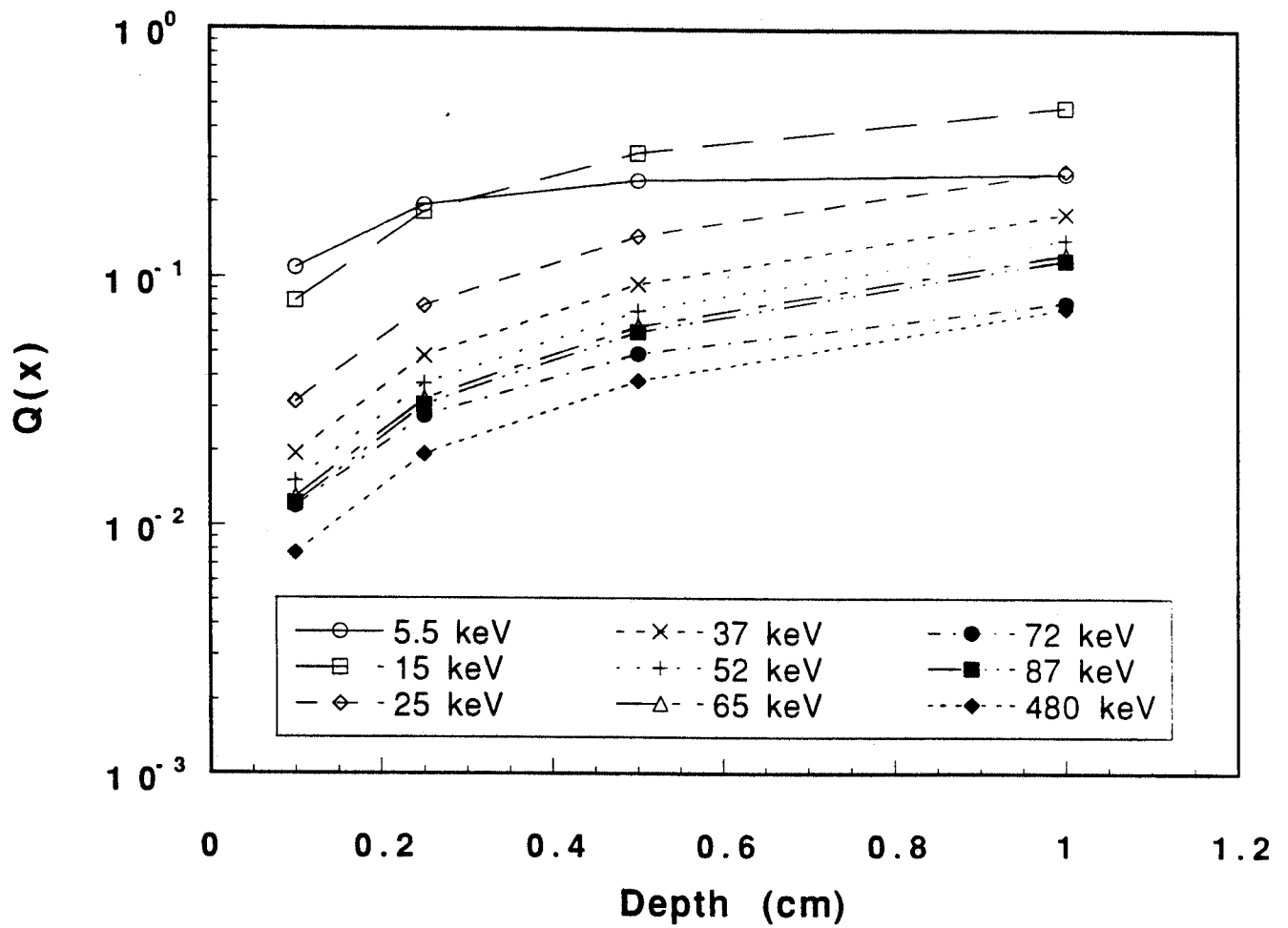

SURFACE TEMPERATURE RISE PER 100 MJ OF X-RAYS  
FOR SILICON-CARBIDE AND GRAPHITE FIRST WALLS

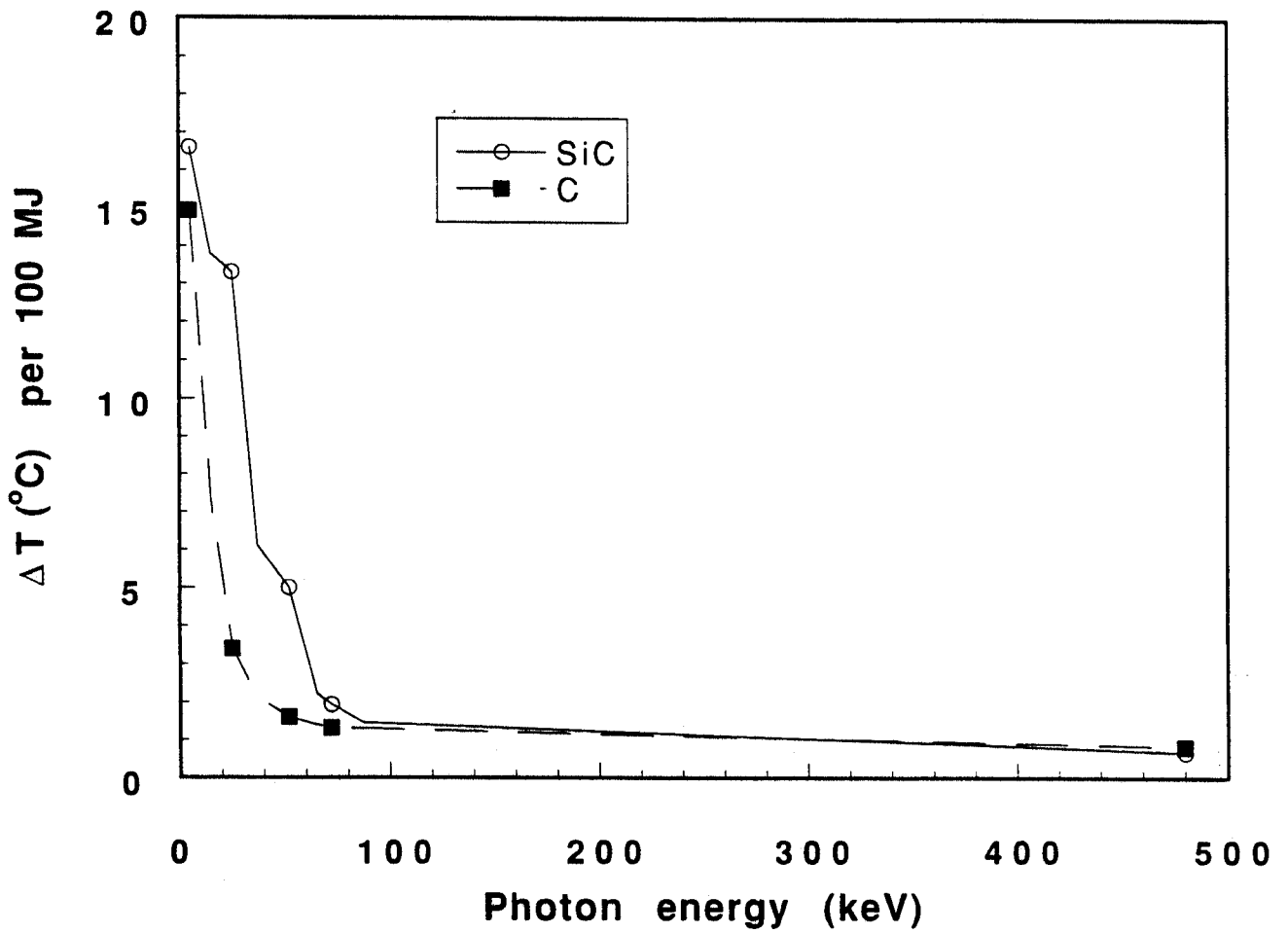



# SUMMARY

- For gas protection schemes, for example, it is possible to allow photons  $> 1\text{keV}$  to reach the first wall, thus the gas density can be reduced.
- For spectra with lower cut-off energy  $> 1\text{keV}$  (e.g. HIBALL), only debris energy need to be attenuated in the cavity gas, if a SiC or C FW is used. (HIBALL target yield: 90 MJ x-rays, 21 MJ debris, 285 MJ neutrons. Min. photon energy  $>10\text{keV}$ ).
- Consequently, the first wall protection scheme, based on silicon-carbide or graphite FW, needs to deal with potential first wall damage due to target debris only.

89

# Condensation of IFE Relevant Liquid First Wall Materials and Their Effects on the NIF Chamber

A Proposal Submitted to  
“Science Use of Nova”  
Lawrence Livermore National Laboratory

Presented by  
Alice Ying  
UCLA  
Oct. 30, 1996

06

The goal is to study the condensation and the vaporization characteristics of a IFE LM ablator plate exposed to the X-rays from a hohlraum heated in the NOVA facility.

---

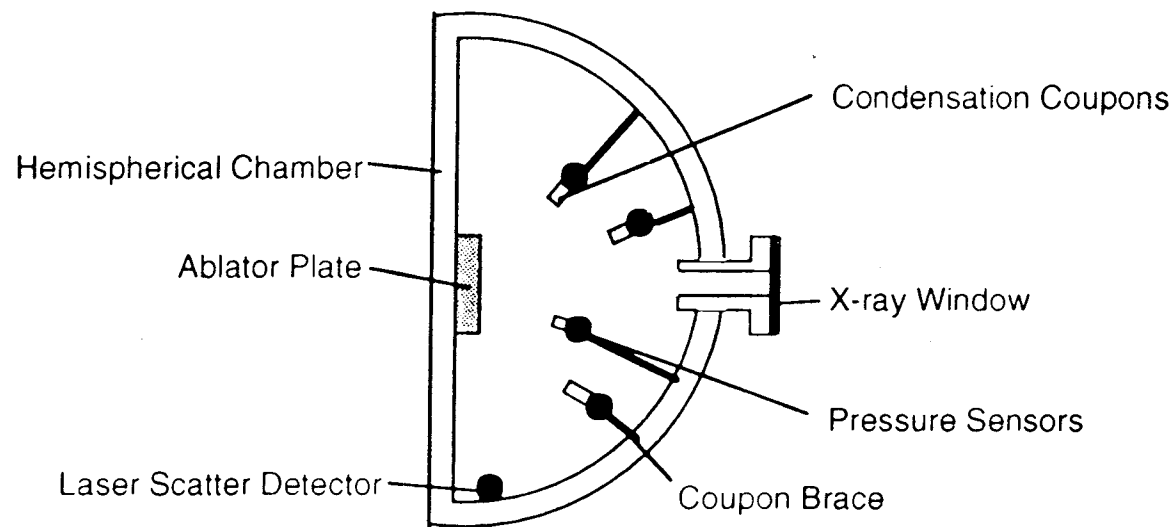

Sketch of hemispherical test chamber with condensation coupon braces extending toward ablation plate.

# Experimental Objectives

- Determine vapor expansion and venting characteristics
- Provide data on
  - the amount and physical characteristics of condensate as a function of distance from the ablator plate, for benchmarking vapor dynamics and condensation codes
  - the amount of vaporized or ejected melt material, for verification of ablation models
- Determine the cleanability of NIF-relevant material coupons using CO<sub>2</sub> cleaning or other NIF cleaning techniques
- Analyze the chemical form of the condensate on different samples when the ablator material is a chemical composite such as Flibe

# Condensation Characteristics Determines Cleanup Compatibility with regard to IFE Liquid Interaction Experiments in NIF

- Water, silicone oil, lead eutectic and molten salts have been proposed to be used as model materials in NIF concerning IFE liquid interactions with debris, x-rays and neutrons.
- Would the CO<sub>2</sub> cleaning technique be able to remove any vaporized or droplet materials which escape through the experimental setup hole and become chamber and debris shield contaminants?

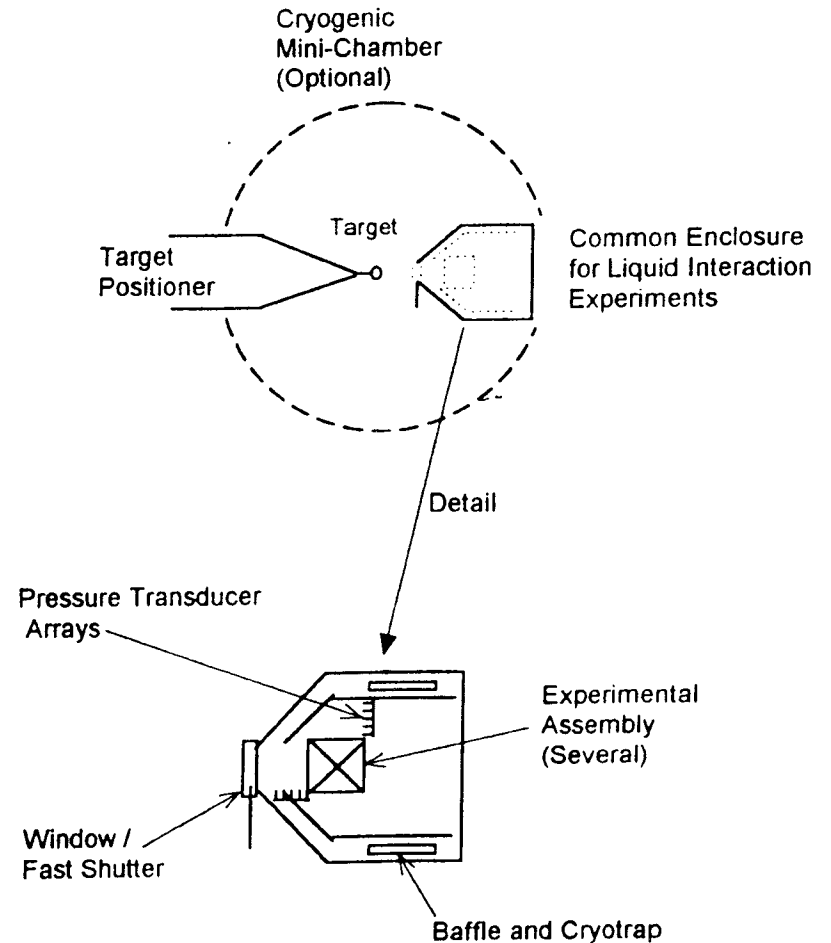

93

# Condensation (and Venting) Provides a Major Challenge for IFE Liquid-Wall Chamber Design

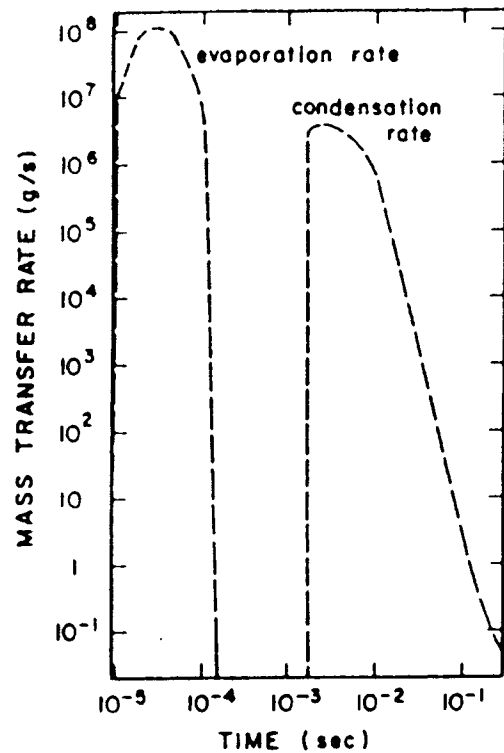

Fig. 7. Evaporation and condensation rates on first surface for mass of vaporized gas = 13 kg  
 [L. Pong et al. Liquid metal condensation in the cavity of the HIBALL heavy ion fusion reactor]

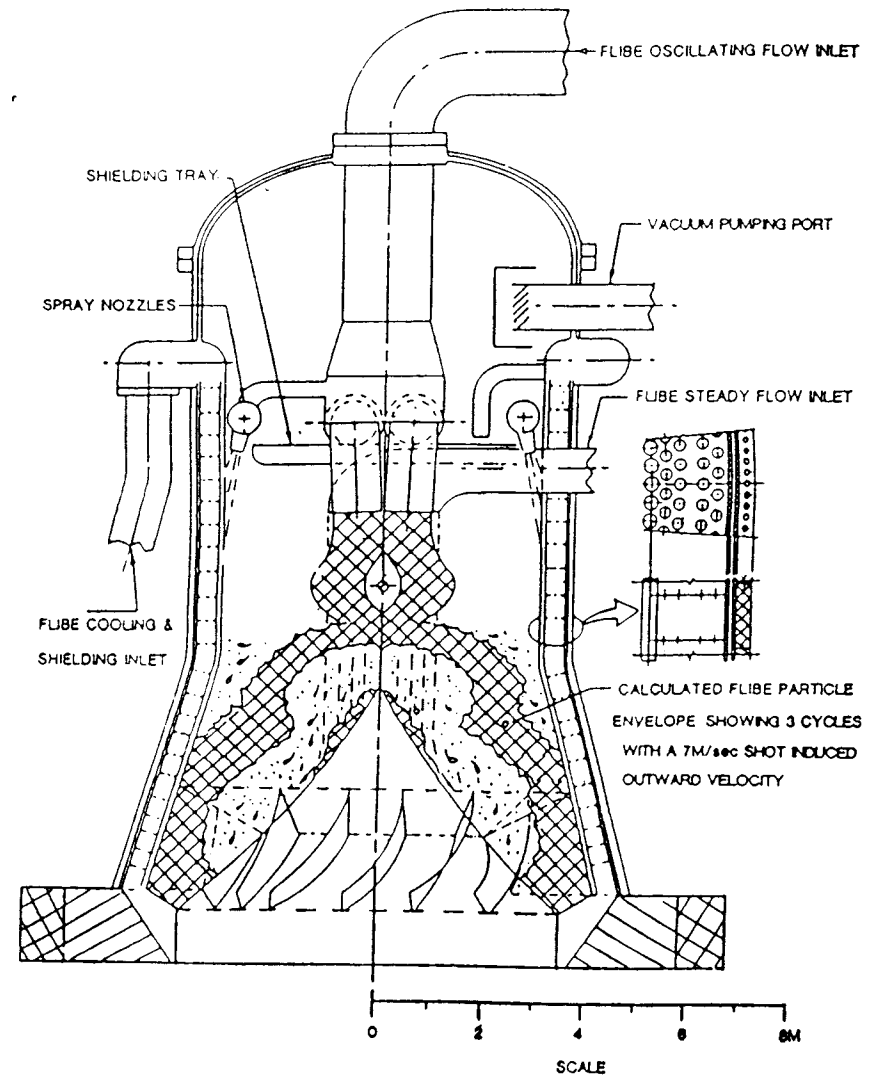
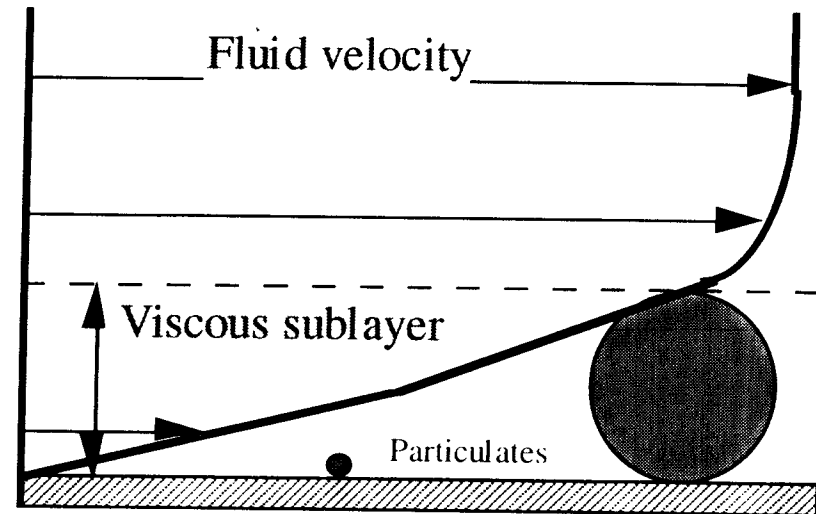

FIGURE 1. HYIFE II REACTOR VESSEL

# Droplet Size and Structure Impact the Efficiency of Gas-Assisted Cleaning Techniques

- Rapid expansion of vapor could condense as:
  - droplets: Previous experiments based on wire explosion technique show that condensate droplet sizes ranged from  $0.02\ \mu\text{m}$  to  $0.2\ \mu\text{m}$
  - surface film (or disc): If the vapor would condense in flight, the subsequent molten droplet generally spreads radically to form a thin disc when impacting on a cold surface



# Alternative Proposed Experimental Setup

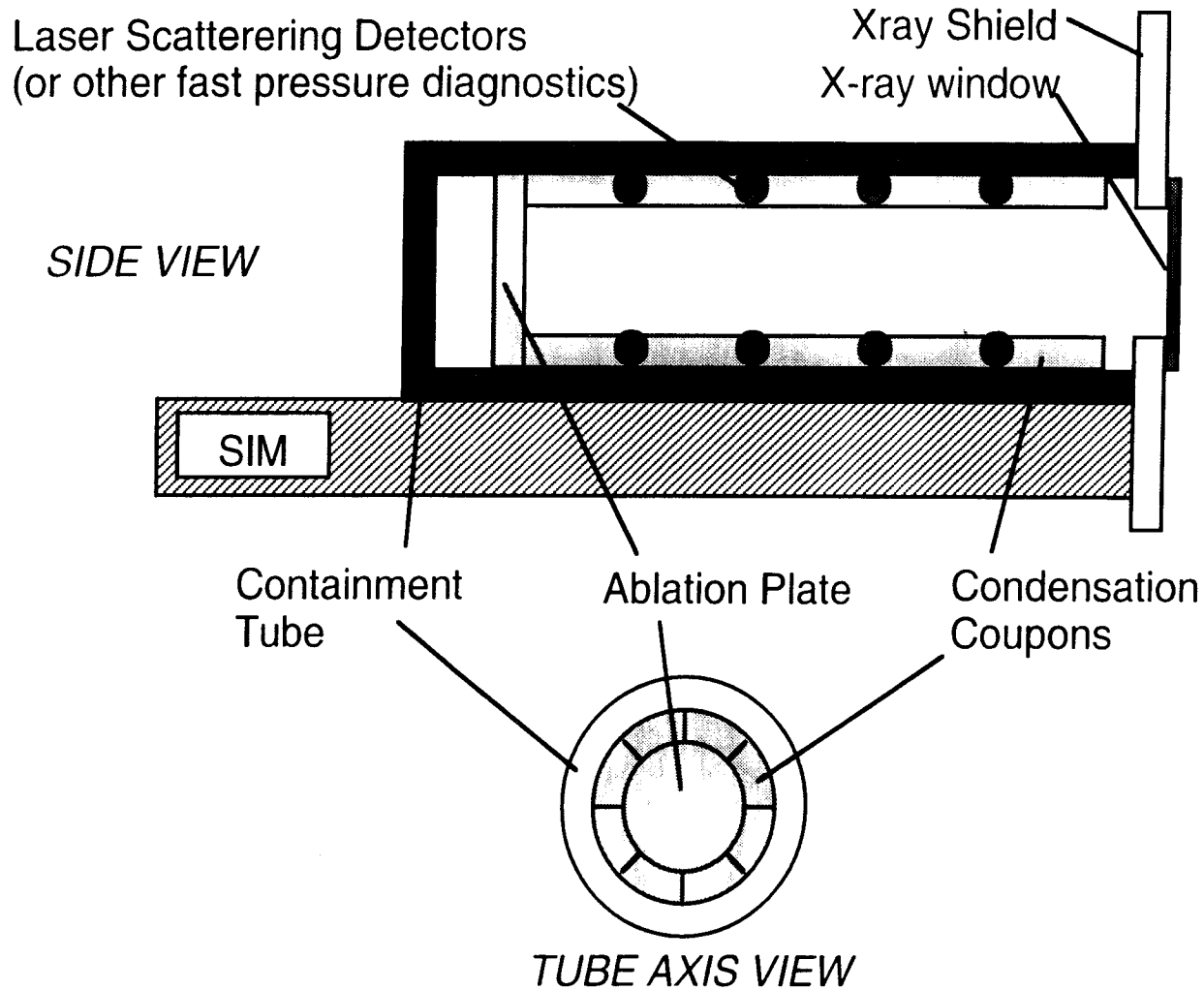

96

Conceptual drawing of expanding vapor condensation experiment



# Diagnostics

- Physical and chemical characterization of condensate samples
- Piezoelectric transducers to measure pressure in the test chamber
- Laser absorption spectroscopy to monitor vapor density, flow velocity, temperature and composition (presence of liquid droplets) of the expanding metal vapor
- Measurements of mechanical response of the [porous] ablator plate during shots and surface characteristics of the plate after the shot