



THE AMERICAN SOCIETY OF MECHANICAL ENGINEERS  
345 E. 47 St., New York, N.Y. 10017

The Society shall not be responsible for statements or opinions advanced in papers or in discussion at meetings of the Society or of its Divisions or Sections, or printed in its publications. Discussion is printed only if the paper is published in an ASME Journal. Papers are available from ASME for fifteen months after the meeting.  
Printed in USA.

## Sensitivity Analysis of MHD Heat Transfer in Self-Cooled Liquid Metal Blankets

D. K. PATEL, A. H. HADID and M. A. ABDOU  
Mechanical, Aerospace and Nuclear Engineering Department  
University of California, Los Angeles  
Los Angeles, CA 90024

### ABSTRACT

In laminar flow heat transfer, the convective capability of the flow depends on the velocity profile. In self-cooled liquid metal blankets of a fusion reactor, the presence of a magnetic field results in steep velocity gradients near the walls. In many locations in the blanket, such as where the flow turns around a bend or where the flow area of the channel and the direction of the magnetic field change, large changes in velocity gradients occur. These result in large changes in the first wall and blanket temperature distribution and substantially affect blanket performance.

Numerical calculations were performed for the flow of an electrically conducting fluid in a plane channel in a magnetic field which is aligned with the direction of the mean flow. Velocity and temperature variations across the duct were evaluated for different velocity profiles at the inlet. It is shown that the presence of the magnetic field retards the development of the velocity profile. The solution of the energy equations for slug, parabolic and skewed velocity profiles shows that the highest heat transfer coefficients are obtained with the latter profile, which has the largest velocity gradient at the wall.

### INTRODUCTION

Liquid lithium (Li) in fusion reactor blankets fulfills a dual purpose of breeding tritium and removing heat from the first wall. The technical issues in the present designs of self-cooled Li/V blankets are being evaluated in the FINESSE (1) study. The toroidal flow is the axial flow around the torus, whereas the poloidal flow is in the circumferential direction. Fig. 1 is a schematic diagram of the poloidal/toroidal blanket, from the BCSS (2) study, where each toroidal flow channel is surrounded by adjacent toroidal channels and several poloidal channels on its back. In the toroidal direction, half of the poloidal channels are colder than the other half by 50-100 °C (those containing the coolant before and after passing through the toroidal channels, respectively).

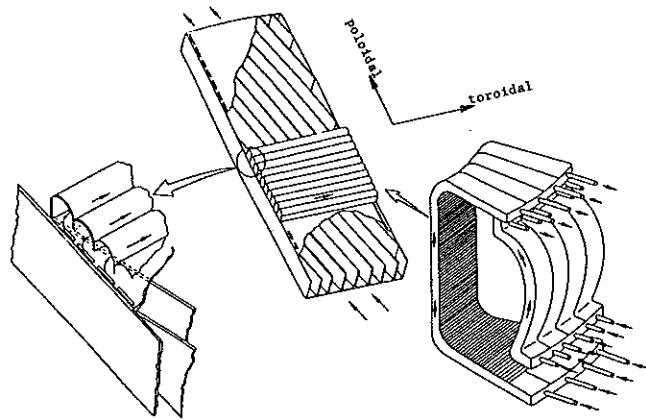

FIG 1 SCHEMATIC OF POLOIDAL/TOROIDAL BLANKET (BCSS)

In the FINESSE study, magnetohydrodynamics (MHD) effects were outlined and shown to present a feasibility issue for self-cooled liquid metal blankets. This is mainly due to the interaction of the moving liquid metal coolant (which is electrically conducting) with the large magnetic flux densities required for plasma confinement. This interaction results in induced electromotive forces, which drive electric currents through the liquid metal and through the duct walls (for conducting walls). When a transverse magnetic field is applied to the flow of a conducting fluid, the electromotive force generated tends to retard the flow in the center of the channel and accelerates the flow in the boundary layers. This results in a steep velocity gradient near the wall and an almost constant profile for the bulk of the fluid. For an axial magnetic field, the flow and the magnetic field are aligned and there is no retarding body force, but the field tends to retard the boundary layer development. This results in

longer flow development lengths and a higher heat transfer rate. MHD flows are usually laminar due to the strong damping effect of the magnetic field on turbulence (3).

Ordinary hydrodynamic (OHD) heat transfer is not too dissimilar from MHD heat transfer. The energy equation is modified by an extra joule heating term. Laminar flow heat transfer in MHD flow is greater than that in OHD flow as a result of steeper velocity gradients at the wall.

In the poloidal/toroidal blanket, the magnetic field is a vector quantity ( $\vec{B}$ ) consisting of the poloidal and toroidal fields. As a result of this, peculiar velocity profiles will exist in the reference blanket, especially at the bends when the poloidal flow changes direction to the toroidal flow. Bocheninskii (4) showed experimentally that skewed velocity profiles will exist at bends. He showed that the maximum velocity shifts towards the center of curvature.

This paper shows that the MHD energy equation can be resolved quite simply once the fully developed velocity profile is known. The assumption of full flow development is valid after 1.50 channel widths (CW) (depending on the orientation of the  $\vec{B}$  field). Numerical analysis of a channel flow in the presence of a magnetic field aligned with the mean flow were carried out. Primarily, the emphasis is given to the flow development lengths (with an axial magnetic field) for different inlet profiles. D'Arcy and Schmidt (5) obtained an integral analytical solution for the entry flow with an axial magnetic field. Shohet, et al. (6), obtained the velocity and temperature profiles for the entry flow in a plane channel with a transverse magnetic field. However, the solutions obtained by D'Arcy, et al., and Shohet, et al., are restricted to axially directed flows and they ignore transverse velocity gradients normal to the field. The present numerical solution of the Navier-Stokes equations is based on the SIMPLE (Semi Implicit Method of Pressure Linked Equation) method developed by Patanker and Spalding (7), where the pressure is linked to the continuity errors through an iterative procedure until the continuity equation is satisfied.

#### ANALYSIS

Fig. 2 illustrates the channel configuration and the coordinate system used (x,y,z). This channel configuration is representative of the toroidal first wall channel in the BCSS blanket of Fig. 1.

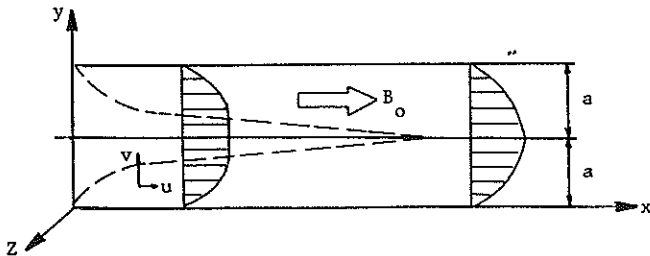

FIG. 2 CHANNEL CONFIGURATION

The velocity at the entrance is either a slug profile or a skewed one. Viscous effects bring the fluid to rest at the wall, causing the formation of a region where the longitudinal velocity varies from zero at the walls to some nearly uniform value in the core of the channel. Since the longitudinal mass flux is less in the boundary layer than in the core region, continuity requires the generation of a transverse fluid velocity away from the walls. This transverse velocity component causes first an increase in the uniform longitudinal core velocity, and second, the transverse component (normal to the applied magnetic field  $B_0$ ) interacts with the field and results in a Lorentz force which impedes the growth of the boundary layer.

The equations solved are:

$$\text{Continuity } \vec{\nabla} \cdot \vec{v} = 0 \quad (1)$$

$$\text{Momentum } \rho(\vec{\nabla} \cdot \vec{v})\vec{v} = -\vec{\nabla}P + \mu \nabla^2 \vec{v} + \vec{j} \times \vec{B} \quad (2)$$

$$\text{Energy } \rho C_p (\vec{\nabla} \cdot \vec{v}T) = K \nabla^2 T + \mu |\nabla \times \vec{v}|^2 + \frac{|\vec{j}|^2}{\sigma} \quad (3)$$

$$\text{OHM's Law } \vec{j} = \sigma(\vec{E} + \vec{v} \times \vec{B}) \quad (4)$$

where

$\vec{v}$ = velocity vector = (u,v,0)	P = pressure
$\vec{j}$ = current density = (0,0, $j_z$ )	$\rho$ = density
$\vec{E}$ = electric field = (0,0, $E_z$ )	$\mu$ = viscosity
$\vec{B}$ = magnetic field = ( $B_0, 0, 0$ )	$\sigma$ = electrical conductivity
T = temperature	$C_p$ = specific heat
	$K$ = thermal conductivity

From Ohm's Law the current density is given by

$$j_z = \sigma(E - vB_0) \quad (5)$$

To determine the constant electric field intensity  $E_z$ , assume that there is no external electrical circuit, i.e., the total current through the fluid and walls in each section is zero.

$$\int_0^{2(a+\delta)} j_z dy = 0 \quad (6)$$

where  $\delta$  is the channel wall thickness.

Substituting from Eq. (5) for  $j_z$  into Eq. (6) and integrating, we get

$$j_z = \sigma B_0(\phi \langle v \rangle - v) \quad (7)$$

where

$$\langle v \rangle = \frac{\int_0^{2a} v dy}{2a} \quad \text{and} \quad \phi = \frac{\sigma_f \cdot a}{\sigma_f \cdot a + \sigma_w \delta}$$

where  $\sigma_w$  is the wall conductivity. For insulating channel wall,  $\phi = 1$  and the electromagnetic force is

$$J_z B_0 = \sigma B_0^2 (\langle v \rangle - v) \quad (8)$$

The effect of this electromotive force is to reduce the transverse velocity component and therefore increase the momentum development length. Fig. 3 shows

the development of the velocity profile along the channel for different values of Hartmann numbers (Ha):

$$Ha = B_0 a \sqrt{\frac{\sigma_f}{\nu}} \quad (9)$$

For  $Ha = 0.0$  and  $Ha = 100.0$ , the velocity is fully developed at  $\frac{x}{2a} = 50$  for both the slug and the skewed inlet profiles. At  $Ha = 1000$ , the velocity profile at  $\frac{x}{2a} = 50$  is still developing. At higher  $Ha$  numbers the development of the velocity profile will be delayed further. Fusion blankets have Hartmann numbers of about  $5 \times 10^4$  to  $5 \times 10^5$ .

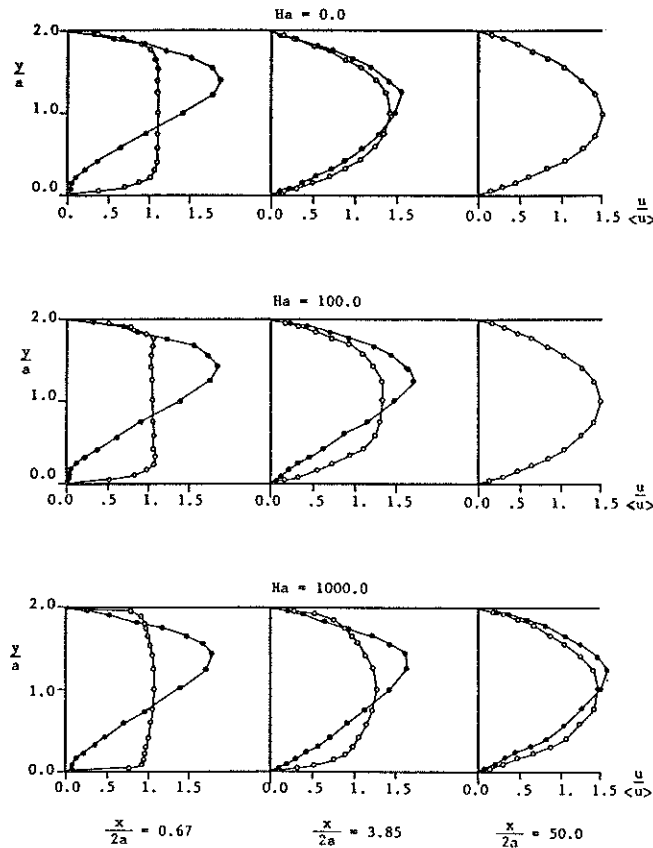

FIG. 3 EFFECT OF AXIAL MAGNETIC FIELD ON THE DEVELOPMENT OF THE VELOCITY PROFILE ALONG THE CHANNEL

-o- Slug Velocity Profile at the Inlet  
 -□- Skewed Velocity Profile at the Inlet

The energy equation in cartesian coordinates can be written as

$$\rho C_p u \frac{\partial T}{\partial x} = K \left( \frac{\partial^2 T}{\partial x^2} + \frac{\partial^2 T}{\partial y^2} \right) + \mu \frac{\partial^2 u}{\partial y^2} + \frac{j_z^2}{\sigma} \quad (10)$$

At high Hartmann numbers, the viscous dissipation term is negligible when compared to the first wall heat flux. The axial conduction term can be shown to be negligible for high Peclet number flows (8). Therefore, the energy Eq. (10) can be written simply as

$$u \frac{\partial T}{\partial x} = \frac{K}{\rho C_p} \frac{\partial^2 T}{\partial y^2} + \frac{j_z^2}{\sigma} \quad (11)$$

The above equation can yield solutions for the sensitivity analysis once the approximation of a developed velocity profile is made. Evaluating the temperature  $T$  using assumed developed velocity profiles will provide a conservative estimate of blanket heat transfer. In the present analysis, a Reynolds number of  $10^6$  and a Peclet number of  $4.4 \times 10^4$  were used. In reality, the flow may not be fully developed if the flow and the field are parallel, and hence the local heat transfer coefficient would be higher.

The assumed velocity profiles are:

$$\frac{u}{\langle u \rangle} = \left( \frac{n+1}{n} \right) \left( \frac{y}{2a} \right)^n \left[ 1 - \left( \frac{y}{a} \right)^n \right] \quad (12)$$

for symmetric power profile

$$\frac{u}{\langle u \rangle} = \left( \frac{n+1}{n} \right) (2n+1) \left( \frac{y}{2a} \right)^n \left[ 1 - \left( \frac{y}{2a} \right)^n \right] \quad (13)$$

for skewed profile

where

$$\langle u \rangle = \frac{\int_0^{2a} u \, dy}{2a}$$

Fig. 4 shows the different velocity profiles used. Eq. (11) is solved for two cases: first, constant, but different wall temperatures, and second, constant heat flux.

let  $T_+$  = first wall constant temperature  
 $T_-$  = second wall constant temperature  
 and  $T_0$  = coolant bulk temperature at inlet.

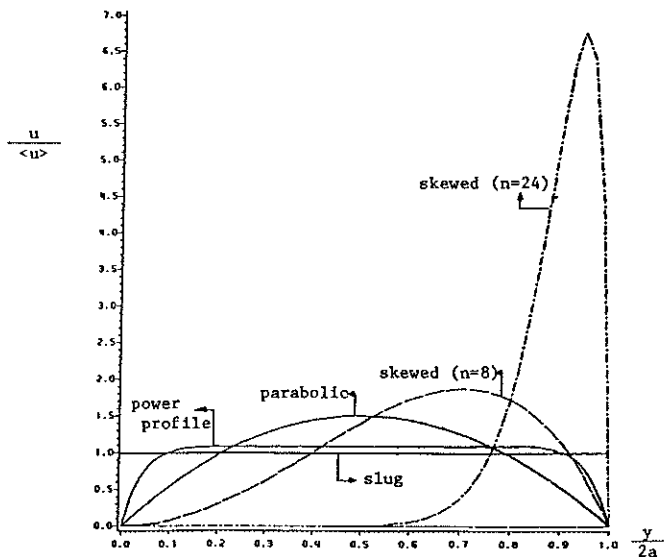

FIG. 4 FULLY DEVELOPED VELOCITY PROFILES USED IN THE SENSITIVITY STUDY

The numerical boundary conditions considered for the first case are  $T_+ = 600 \text{ }^\circ\text{C}$ ,  $T_- = 300 \text{ }^\circ\text{C}$  and  $T_0 =$

200 °C.  $\theta$  = non-dimensional temperature =  $\frac{T - T_0}{T_w - T_0}$ .  
 The boundary conditions for the second case are  $q_w =$   
 heat flux at the first wall = constant and  $\frac{\partial T}{\partial y} = 0$  and  
 $\theta = \frac{K}{q_w h} (T - T_0) = 1$  at first wall, = 0 at second wall,  
 where  $h$  = heat transfer coefficient. The local Nusselt  
 number evaluated at the first wall is

$$Nu_x^+ = \frac{-\frac{\partial T}{\partial y} \Big|_{y=a} D_H}{T_b - T_w} \quad (14)$$

where

$$T_b = \frac{\int_0^{2a} u T dy}{\int_0^{2a} u dy}$$

Fig. 5 shows the variation of the local Nusselt number  $Nu_x$  along the channel for the constant wall temperature case. It is seen that the skewed profile gives the highest local Nusselt numbers. Fig. 6 for the constant heat flux case shows similar behavior but the local values of  $Nu_x$  are higher than the former. Figs. 7a and 7b show the temperature across the channel at different locations along the channel for the constant wall temperature. Figs. 8a and 8b show the temperature cross the channel for the constant heat flux case.

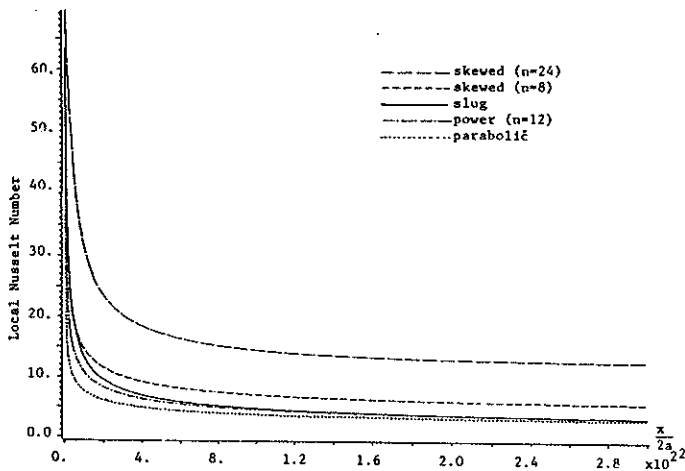

FIG. 5 LOCAL NUSSELT NUMBER FOR DIFFERENT VELOCITY PROFILES (constant wall temperature)

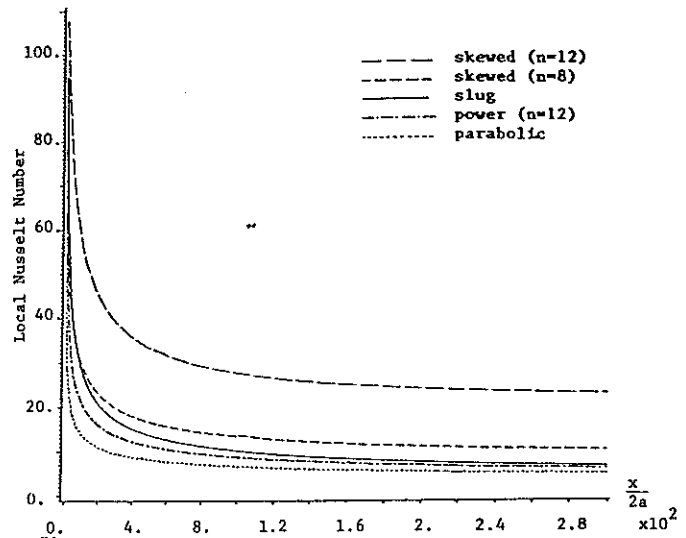
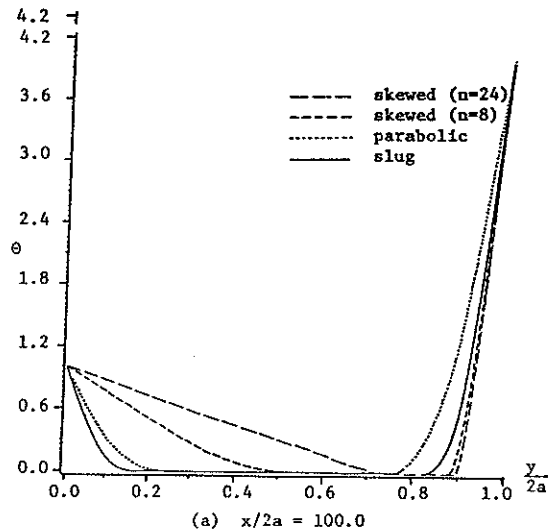
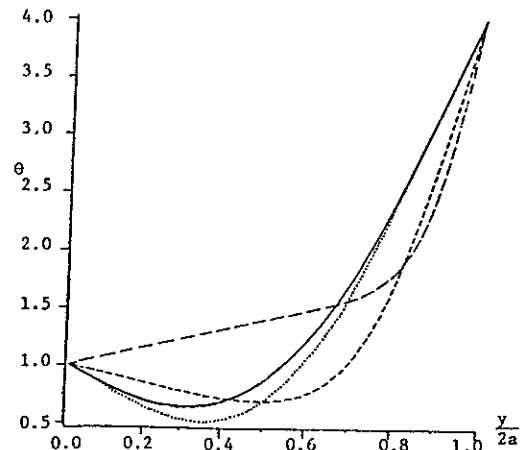

FIG. 6 LOCAL NUSSELT NUMBER FOR DIFFERENT VELOCITY PROFILES (constant heat flux)



(a)  $x/2a = 100.0$



(b)  $x/2a = 3000.0$

FIG. 7 TEMPERATURE DEVELOPMENT FOR DIFFERENT VELOCITY PROFILES

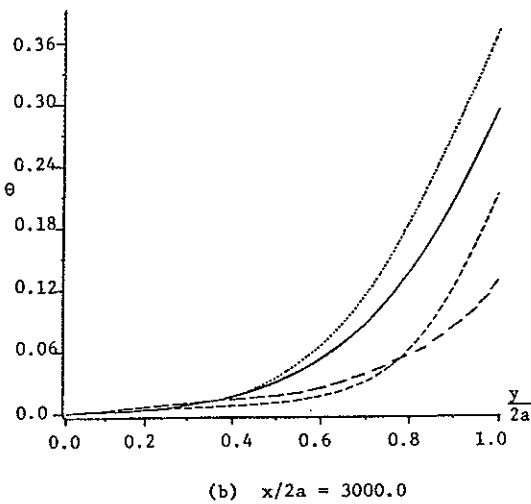
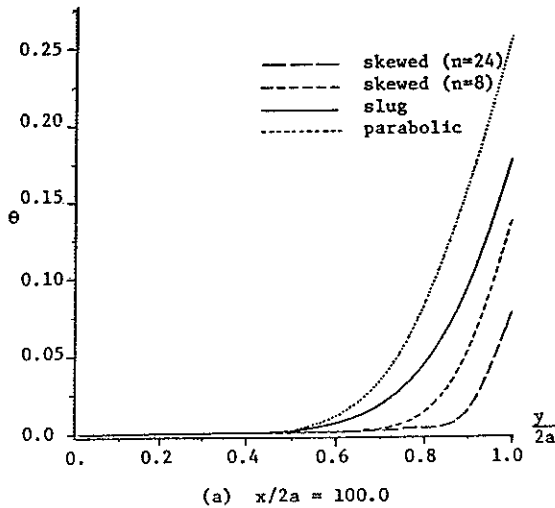

FIG. 8 TEMPERATURE DEVELOPMENT FOR DIFFERENT VELOCITY PROFILES (constant heat flux)

CONCLUSION

It was shown from Fig. 3 that the effect of an axial magnetic field aligned with the mean flow is to delay the velocity development. In the BCSS blanket design, it is important to distinguish between the flows in the toroidal and poloidal directions. The flow in the poloidal direction is under intense transverse toroidal field and the velocity profile will be fully developed in a few channel widths. Therefore, the assumption of fully developed flow is valid when the flow is in the poloidal direction. But when the flow turns around a bend, i.e., from the poloidal to the toroidal direction, the velocity profile would be skewed, most likely towards the first wall. Since the field and flow are parallel, the velocity profile will be developing and full flow development length is of the order of 100 channel widths. In this case, the assumption of a developed velocity profile is not strictly true since at inlet we would get slightly higher local Nusselt numbers. Accurate treatment of

the blanket requires considering the non-developing regime over most of its length inside the reactor.

The effect of the assumed developed velocity profile on the heat transfer rate was shown in Fig. 5 for constant wall temperature, and was shown in Fig. 6 for constant wall heat flux. It can be seen that the latter case gives higher  $Nu_x$  than the former. For fusion blanket analysis, an appropriate boundary condition is one of a constant wall heat flux. Figs. 5 and 6 show that the local Nusselt number increases as the velocity profile is skewed towards the first wall. Table 1 shows the constant value the Nusselt number reaches along the channel for the different velocity profiles. The constant wall heat flux condition shows higher Nusselt numbers than the constant wall temperature. In practical fusion blankets, the flow is in the thermal entry region.

TABLE 1 MEAN NUSSLETT NUMBER FOR DIFFERENT VELOCITY PROFILES AND TWO BOUNDARY CONDITIONS

PROFILE	CONSTANT TEMP. BOUNDARY CONDITION	CONSTANT HEAT FLUX CONDITION
Slug	5.40768	11.14368
Parabolic	3.97543	6.95077
N = 4	4.35336	7.80441
N = 12	4.92338	9.35026
Skewed		
N = 2	5.25836	
N = 4	7.56256	14.11627
N = 6	9.70375	18.33974
N = 12	15.81046	29.32225

REFERENCES

- M.A. Abdou, et al., "FINESSE: Technical Issues and Requirements of Experiments and Facilities for Fusion Nuclear Technology," University of California, Los Angeles, PPG-909, also UCLA-ENG 85-39 December 1985.
- M.A. Abdou, et al., "Blanket Comparison and Selection Study - Final Report," ANL/FPP-84-1, September 1984.
- V.B. Levin, "On the Stabilizing Effect of a Longitudinal Magnetic Field Upon the Nonhomogeneous Turbulent Motion of a Conducting Fluid," *Magneto-hydrodynamics*, 1:2, 1965.
- V.P. Bocheninskii, A.V. Tanonaev and V.V. Yakovlev, "Experimental Investigation of the Flow of an Electrically Conducting Liquid in Curved Tubes of Circular Cross-Section in an Intense Magnetic Field," *Magneto-hydrodynamics*, 4, 1977, 61-65.
- G.P. D'Arcy and P.S. Schmidt, "Magneto-hydrodynamic Entry Flow for a Plane Channel in an Axial Magnetic Field," *Journal of Fluid Mechanics*, 80:2, 1977.
- J.L. Shohet, et al., "Velocity and Temperature Profiles for Laminar Magneto-hydrodynamic Flow in the Entrance Region of a Plane Channel," *Phys. Fluids*, 5:5, 1962.

7. S. V. Pantankar, "Numerical Heat Transfer and Fluid Flow," McGraw Hill, New York, 1980.
8. Chia-Jung Hsu and G.C. Lindaner, "The Influence of Axial Conduction on the Thermal Entry Region Heat Transfer in MHD Channel Flow," Nuclear Science and Engineering, 32, 1968, 16-29.