

**SIMPLE ANALYSIS OF WALL THICKNESS VERSUS NEUTRON
FLUX OF A HELIUM-COOLED TUBE
AND
RECOMMENDATIONS TO THE APEX PROGRAM**

by
CLEMENT WONG, CHANDU BAXI, and ELMER REIS

Presented at
APEX Project Meeting
UCLA, Los Angeles, California

JANUARY 12-14, 1998

INTRODUCTION

- **Question**
 - **What is the neutron flux limit of a helium-cooled first wall?**
- **Approach**
 - **Pick a high power density first wall/blanket design as an example**
 - **Identify design limits and criteria**
 - **Define heat source and coolant temperature assumptions**
 - **State thermal hydraulics models**
 - **Determine tube wall thickness versus neutron wall loading within nearest design limit**
- **Conclusions/Recommendations**
- **Recommendations to the APEX program**

GA-LAR NESTED SHELL HIGH POWER DENSITY FIRST WALL/BLANKET (DEFINITION OF FIRST WALL GEOMETRY)

GA-LAR Design

R, m	2.9
a, m	2.08
k	3
A	1.4
P _{fusion} , MW	4909
Q	4.2
Blanket M	1.4
Γ _{n-average} , MW/m ²	8
φ-average, MW/m ²	1.95*
# of outboard module	24
P _{e-net} , MW	1998
COE, mill/kWh	52.8

*Core radiation using Kr as the radiating impurity

Coolant: Helium @ 15 MPa

T_{in} = 250°C

T_{out} = 650°C at exit of blanket module

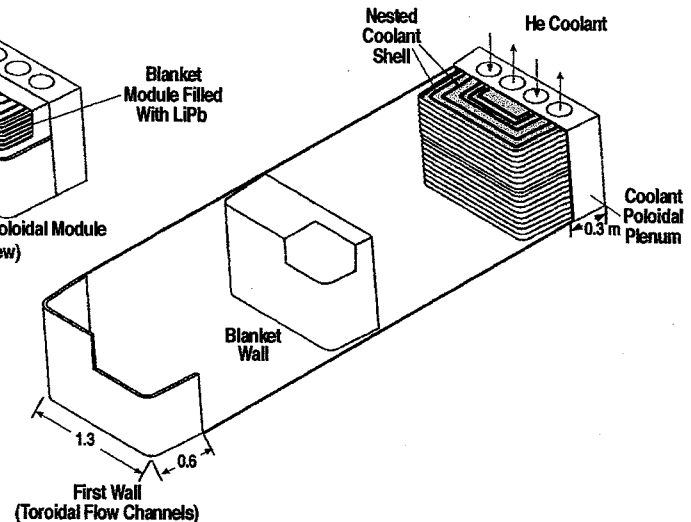

Structural material: V-alloy

Breeder: LiPb (or Li)

- The first wall is a separate shell
- Simple coolant channel in a U-shape geometry. First wall length = 1.3 m (toroidal length), blanket thickness = 0.6 m (radial depth)
- Blanket coolant shells radial separations can be adjusted to the level of local volumetric power generation (i.e. to different neutron wall loading)
- He/V-alloy compatibility issue to be resolved by coating (e.g. aluminized layer) or bi-metallic tube (e.g. 50 to 100 μ bonded FS layer between the He and V-alloy interface)

FIRST WALL DESIGN LIMITS AND CRITERIA

- V-alloy

- V-alloy $T_{\min} \sim \geq 400^{\circ}\text{C}$ (for irradiated locations)

- V-alloy $T_{\max} \leq 700^{\circ}\text{C}$

- Design within stress limits: Primary stress $< S_m = 120 \text{ MPa}$

Total stress = primary + secondary $< 3 S_m = 360 \text{ MP}$

- Coolant velocity and pressure drop

- Design within vibration limits:

Coolant max. velocity \ll sonic speed = 1622 m/s

@ 286°C and 15 MPa

\ll critical vibration velocity $\sim 800 \text{ m/s}$

- $\Delta P_{fw}/P < 10\%$ for CCGT

- FW PP/Mod. $P_{th} < 5\%$

FIRST WALL HEAT SOURCE AND COOLANT TEMPERATURE ASSUMPTIONS

- Volumetric power contributed from rectangular V-alloy unit shell with 1 mm first wall eroded layer (eroded layer allowed to have $T_{\max} > 700^{\circ}\text{C}$)
- Heat flux input = 1/4 (Neutron wall loading) i.e. transport power evenly distributed to first wall and divertor (core radiation enhanced)
- Blanket $M=1.4$
- Coolant exit temperature determined by the fraction of power carried by the first wall
- Side wall volumetric heat input neglected
- Coolant temperature variation at input, middle and outlet of first wall tube included in coolant properties changes

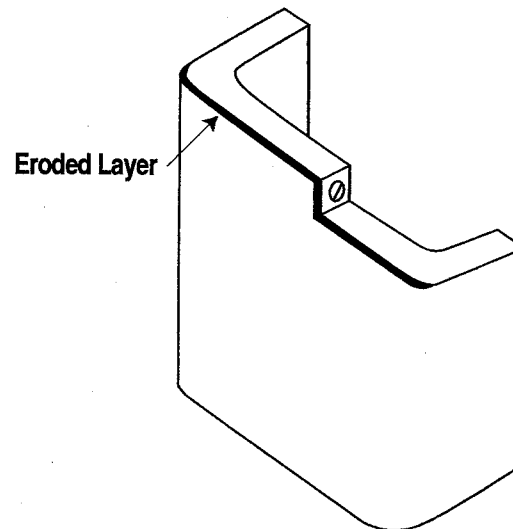

He - Cooled First Wall Schematic
(can be in channels or tube-bank configuration)

APPROXIMATE THERMAL HYDRAULICS MODELS FOR SWIRL TAPE

- Helical tape insert used (0.5 mm thick strip) to enhance heat transfer and reduce impact from one-sided heating
- Hydraulic diameter for helical tape tube:

$$d_{hy} = 4 \frac{\text{flow area}}{\text{wetted parameter}} = 4 \left[\frac{\pi r^2 - \text{tape area}}{\pi D + 2D} \right]$$

- Heat transfer coefficient:

$$h_{eq} = 1.8 h = 1.8 \left[0.023 \text{Re}^{0.8} h^{0.4} \right]$$

- Friction factor:

$$f_{eq} = 3f = 3 \left(\frac{0.186}{\text{Re}^{0.2}} \right)$$

TUBE WALL THICKNESS VERSUS MAXIMUM NEUTRON WALL LOADING

Di ² mm	Γ_n -max ¹ MW/m ²	Δx mm	He-V _{max} m/s	T _{min.} V-alloy ³	T _{max} -V-alloy °C	σ_{total} MPa	$\sigma_{primary}$ MPa	PP/P _{th} %
10	5.6	5	92	366	698	248	15	0.72
10	8.4	3.1	111	393	695	236	24	0.96
10	11.2	2.2	131	413	697	233	34	1.2
10	14	1.65	150	430	697	231	45	1.5
10	16.8	1.3	170	443	697	232	58	1.9
8	5.6	5.7	142	329	700	278	11	2.0
8	8.4	3.7	168	349	699	271	16	2.6
8	11.2	2.7	193	365	700	267	22	3.2
8	14	2.1	219	378	700	263	29	3.9
8	16.8	1.65	243	389	696	258	36	4.6

¹ Γ_n -max taken as 1.4 x Γ_n -average

²Tube inside diameter, from primary stress consideration, Di=10 mm has a min. Δx of 0.625 mm, Di=8 mm has a min. Δx of 0.5 mm

³Futher detailed design can increase this T_{min} at the first wall coolant inlet if necessary

TUBE THICKNESS VERSUS MAXIMUM NEUTRON WALL LOADING

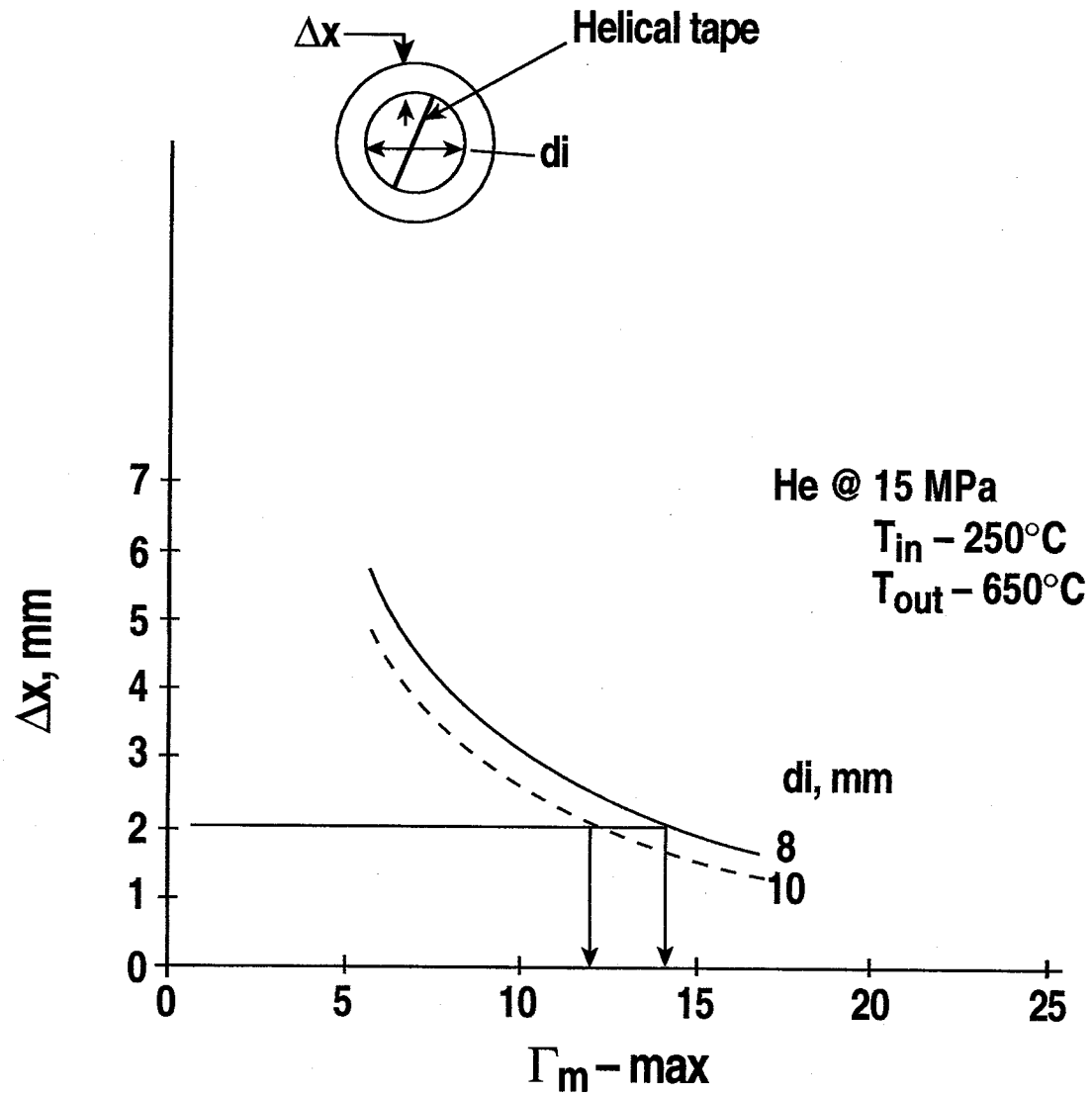

CONCLUSIONS

- Neutron wall loading limit is design dependent and should be optimized to the specific design
- The optimum helium coolant routing is to cool the first wall and then the rest of the blanket volume
- Present design is limited by V-alloy T_{max}
- Based on the selected design geometry and parameters, at an arbitrary structural wall thickness of 2 mm, a simple tube can handle maximum neutron wall loading of $> 14 \text{ MW/m}^2$ and therefore average neutron wall loading of $> 10 \text{ MW/m}^2$, while all the design criteria can be met. Further optimization is possible

RECOMMENDATIONS

- This simple tube design should be re-examined and evolved to a first wall design with high reliability. Special attention should be given to the joining of coolant channels to the plenum
- More advanced heat removal methods can be used (Ref. Baxi, Rosenfeld, Izenzon)

$h \sim$ factor of 2 to 10

$$\frac{PP}{Q} \sim \frac{f}{St^2} \sim \frac{f}{h^3}$$

$f \sim$ factor of 3 to 20

- The design criteria of the ASME code for ductile materials limits stresses to a safe level consistent with experience. The ITER design criteria addresses the effects of irradiation (embrittlement, swelling, creep) should be applied
- Multi-dimensional thermal and structural evaluation should be evaluated with the inclusion of tokamak off-normal conditions
- Approaches for the compatibility design between helium-coolant and V-alloy should be developed (e.g. coating via aluminization and bi-metallic approaches)
- Corresponding high pressure systems should be developed, e.g. CCGT and pipings
- High pressure system safety should be addressed

RECOMMENDATIONS TO THE APEX STUDY

- **High power density first wall design**
 - GA-LAR design shows that a 2 GWe device at an average neutron wall loading of 8 MW/m^2 , and the use of helium-cooled, V-alloy, liquid metal blanket can have a competitive COE of ~53 mill/kWh
 - I would like to propose, the helium-cooled, V-alloy first wall and liquid metal blanket design to be an option to be evaluated by APEX
 - The goal is to further reduce the minimum reactor net-electrical output with engineering $Q > 4$ and the COE $< 53 \text{ mill/kWh}$

- **APEX program**
 - For the APEX study, the general approach of economic fusion power via the route of high power density is clear. However, the quantification and interaction with plasma requirements of different concepts (tokamak, LAR and alternates) are not obvious
 - A physics and engineering system evaluation task group should be formed to generate key trade-off parameters for tokamak, LAR and alternate concepts (e.g. impurities effects to different regimes of plasma operation for different concepts)